

## CHAPTER VI. -- FOUNDATION REPAIR & DAMP PROOFING

### TABLE OF CONTENTS

<u>30.50 (1.)</u>	Application for Building Permit
<u>30.50 (2.)</u>	Best Management Standards for Foundation Repair
<u>30.50 (3.)</u>	Definitions
<u>30.50 (4.)</u>	Conditions Requiring Foundation Repair
<u>30.50 (4.)(a.)</u>	Wet Walls or Water Seepage at the Base or Above (No Movement)
<u>30.50 (4.)(b.)</u>	Wet Walls or Water Seepage Two Courses and Above (No Movement)
<u>30.50 (4.)(c.)</u>	Water Seepage through Floor Slab
<u>30.50 (4.)(d.)</u>	High Water Table
<u>30.50 (4.)(e.)</u>	Leaning or Bowed CMU Walls/Wall Deflection less than 1" (No Movement)
<u>30.50 (4.)(f.)</u>	CMU Wall Step Cracks with No Movement
<u>30.50 (4.)(g.)</u>	Leaning or Bowed CMU Walls/ Wall Deflection less than 1" (Some Movement)
<u>30.50 (4.)(h.)</u>	Leaning or Bowed CMU Walls/Wall Deflection 1" or More
<u>30.50 (4.)(i.)</u>	CMU Walls Sheared at Base/Wall Slide Less than ½"
<u>30.50 (4.)(j.)</u>	CMU Walls Sheared at Base/Wall Slide ½" or more
<u>30.50 (4.)(k.)</u>	Dropped, Settled or Rotated Footing Under CMU Wall
<u>30.50 (4.)(l.)</u>	Poured Concrete, Brick or Stone Walls with Water Seepage (No Movement)
<u>30.50 (4.)(m.)</u>	Poured Concrete walls, leaning or bowed/wall deflection less than 1"
<u>30.50 (4.)(n.)</u>	Poured Concrete walls, Leaning or bowed/ Wall deflection 1" or more
<u>30.50 (4.)(o.)</u>	Brick walls leaning or bowed/wall deflection less than 1"
<u>30.50 (4.)(p.)</u>	Brick Walls Leaning or Bowed/ Wall Deflection 1" or more
<u>30.50 (5.)</u>	Site Specific Engineering
<u>30.50 (6.)</u>	Procedure for Wall Repair Including: Excavation, Waterproofing & Reinforcement
<u>30.50 (7.)</u>	Procedure for Interior Drain Tile Repair without Excavation
<u>30.50 (8.)</u>	Wall Drainage Board Specification
<u>30.50 Appendix A</u>	- Drain Tile Test Procedure
<u>30.50 Appendix B</u>	- Site Specific Engineering Report
<u>30.50 Appendix C</u>	- Foundation Repair Details

### 30.50 FOUNDATION REPAIR & DAMPPROOFING

- (1.) Application for Building Permit shall include a statement of the existing defects and an analysis of the cause of those existing defects to ensure that all conditions responsible for foundation defects are corrected. A plan defining the scope of work along with specifications shall be submitted for approval prior to the issuance of a Building Permit.
- (2.) Except as otherwise permitted by the Authority Having Jurisdiction, foundation repair work shall be performed in accordance to the Best Management Standards for Foundation Repair as described in the this Chapter.

(3.) Definitions

- (a.) As-Built Condition – A basement wall with NO DEFECTS as constructed immediately following either installation of the concrete masonry or poured concrete wall before backfilling. The wall can be said to have no defects if the corners and/or the walls were constructed out of plumb with no cracks or movement. Additionally, the wall is not defective if repair has been done 10 years or more prior to the time of inspection and there are no cracks or movement. Shrinkage cracks with no movement of the wall area not considered a structural defect. Measurement of a wall is done by averaging the measurements of both corners compared to the measurement at the center of the wall.
- (b.) Backfill – Material used to fill in an excavation.
- (c.) Bleeders – Concrete or plastic pipe that is installed through the footing or foundation wall to allow transfer of water from the exterior drain tile to the interior drain tile.
- (d.) Concrete Block – Concrete masonry unit used in basement wall construction. Concrete block is commonly used in nominal 8", 10" or 12" widths and is typically 8" tall by 16" long with 2 open cells in the block. The concrete blocks are stacked with alternating vertical joints using mortar between the joints to hold the block together.
- (e.) Downspout – Aluminum or galvanized steel pipe that directs water collected in the rain gutters down to the ground and away from the building.
- (f.) Drain Tile (Interior or Exterior) – Concrete or plastic perforated pipe used underground to collect water and direct it to the sump crock. Exterior drain tile is placed on the outside of the building at the elevation of, or on top of the footing, consistent with existing conditions. Interior drain tile is placed around the inside perimeter of the building just below the floor slab. Drain tile is encased in clear aggregate to allow for water drainage to the pipe.
- (g.) Drain Tile Test – A test of the function of the interior drain tile. The drain tile test is performed by: cutting through the floor slab to access the drain tile, flushing water into the drain tile and observing the amount of water entering the sump crock. A diminished water flow indicates a plugged or crushed drain tile. See Appendix A
- (h.) Efflorescence (Scale Stains) – White mineral deposits showing on face of masonry due to water leaching through the masonry to the dry surface.
- (i.) Epoxy - Material used to repair cracks in concrete or masonry. Epoxy is a material that can be injected into wall cracks and when cured forms a very strong bond with the base material. Epoxy can be used for the structural repair of walls.
- (j.) Expansive Clay Soils - Expansive soils contain minerals that are capable of absorbing water, which enables the soils to increase in volume. Expansions of ten percent or more are common. This change in volume can exert force on a building or other structure causing substantial damage.
- (k.) Grade – Reference to the pitch of the exterior ground surface adjacent to the building.

- (l.) Horizontal Cracks – Usually associated with bowing or displacement of masonry walls that are not plumb vertically and/or horizontally.
- (m.) Laser Level– Instrument, which emits a beam of light on a certain horizontal or vertical plane. This plane can be used to measure deflection and/or movement of an adjacent plane.
- (n.) Level – Instrument used for measuring the plane of a vertical or horizontal surface.
- (o.) Palmer Valve – Storm water discharge valve typically located in the side wall of the floor drain, designed to prevent backflow of sanitary sewer into storm water system.
- (p.) Pilaster – A projection of masonry or a filled cell area of masonry for the purpose of bearing concentrated loads or to stiffen the wall against lateral forces.
- (q.) Plumb Line – Tool for measuring wall deflection consisting of a weight and string. The string is attached at the top of the wall and the weight is at the end of the string located near the floor providing a straight vertical reference line. Measurements are taken from the string to the wall to determine the amount of horizontal deflection in the wall.
- (r.) Polyurethane – Material that can be injected into wall cracks to prevent water seepage. Polyurethane should not be used for the structural repair of walls.
- (s.) Poured Walls – Solid concrete walls that are constructed by setting concrete wall forms, installing steel reinforcing bars and pouring concrete into the forms to create a wall.
- (t.) Radon Gas – Odorless and colorless slightly radioactive gas that can seep into basements through floor or wall cracks. At certain concentrations Radon Gas is considered a health hazard. For more information on Radon Gas, refer to [www.epa.gov/radon](http://www.epa.gov/radon).
- (u.) Seepage – Water infiltration through masonry walls or floor slab. Seepage is evidenced by damp or wet masonry walls or concrete floor and is an indication that the basement drainage system is overloaded or not functioning correctly.
- (v.) Spud Pipe – Steel pipe, 3/4" to 1" diameter that is driven into the soil around the perimeter of the building. Water is injected into the soil thru the pipe just above the elevation of the drain tile to test the function of the drain tile.
- (w.) Steel Restraints – Wall reinforcing used to prevent further movement in basement walls. Steel restraints are typically composed of steel tubes placed vertically against the basement walls at a 32" or 48" spacing.
- (x.) Step Cracks – Cracks in masonry walls that follow the vertical and horizontal joints in the masonry in a stepped fashion. Step cracks can be due to horizontal wall deflection, foundation settlement or shrinkage of concrete masonry.
- (y.) Site Specific Engineering – Analysis of existing conditions by a Registered Professional Engineer or Architect to document site conditions and provide repair recommendations. See Appendix B.

- (z.) Stone Backfill – Clear crushed aggregate 3/4” to 1” diameter used to backfill excavations. Stone backfill allows for water to migrate easily towards the drain tile located at the basement footing elevation. Additionally, stone backfill will have minimal settlement around the perimeter of the building after backfilling.
- (aa.) Sump Crock – Concrete, steel or plastic basin placed below the floor slab in the lowest area of the building for collecting water from drain tile. Top rim to extend minimum 1” above floor.
- (bb.) Sump Pump – Submersible or upright pump located in sump crock to pump water out and away from the building.
- (cc.) Tuckpoint – Term used for the repair of cracks that occur in the joints in masonry walls. Tuckpointing involves the removal and replacement of the mortar between masonry units where cracking along the joints has occurred.
- (dd.) Wall Drainage Board – One piece corrugated or ribbed plastic panel that is placed to form an angle on top of the wall footing and against the masonry wall. The panel extends a minimum of 1” above the floor slab elevation. The wall drainage board is used to drain water from the cores of concrete masonry walls to the interior drain tile. (See 30.50(8.) for product specifications).
- (ee.) Wall Deflection – The amount of horizontal movement in a basement wall at any given location with respect to its vertical plane.
- (ff.) Wall Irregularities – Masonry wall corners or areas in the wall that have thickened sections. Examples of wall irregularities include foundations for masonry fireplaces and wall pilasters.
- (gg.) Wall Slide (Base Shear) – Horizontal movement of basement wall, usually occurring at the bottom section of the wall.

(4.) Conditions Requiring Foundation Repair

(a.) Wet Walls or Water Seepage at the Base (No Movement)

1. Wet foundation walls or signs of water seepage along the base the wall. Water puddles or streams from heavy rains. Walls often have dampness, presence of mildew or efflorescence. Walls show no cracking, bowing or displacement.

2. Testing

- a. Check palmer valve for correct operation. Check with local jurisdiction if repair of palmer valve is permitted (per local requirements).
- b. Break open floor, test interior drain tile for correct flow to palmer valve, or sump pump. See Appendix A.
- c. Use water spud pipe, inserted along outside of wall to exterior drain tile, to introduce water to check exterior drain tile operation.
- d. Check for proper grade away from exterior walls and adequate gutters & downspouts.

### 3. Standard Repairs

- a. Extend downspouts, improve grade by increasing pitch away from buildings to the greatest extent possible.
- b. Install, replace, or repair Sump pump. Sump pump must meet State and local Plumbing and Electrical Code.
- c. Replace some or all of interior drain tile as necessary. Drain first block into interior drain tile using an approved one-piece wall drainage board that provides water passage and lateral support to first course of block. Wall drainage board is to be 1" minimum higher than floor. Use a wall drainage board that can be caulked for retarding radon migration. Install to manufactures specification. See 30.50(7.) & Appendix A.
- d. If it is determined that it is necessary to excavate to make repairs to the foundation see 30.50(6.).

### 4. Maintenance After Repair

- a. Keep downspouts extended.
- b. Maintain positive pitch of grade away from house.

### 5. No Site Specific Engineering required.

## (b.) Wet Walls or Water Seepage Two Courses and Above (No Movement)

1. Wet foundation walls or signs of water seepage two courses or higher above the base of the wall. Walls often have dampness, presence of mildew or efflorescence. Walls show no cracking, bowing or displacement.

### 2. Testing

- a. Check for proper grade away from exterior walls and adequate gutters & downspouts.

### 3. Standard Repairs

- a. Extend downspouts, improve grade by increasing pitch away from buildings to the greatest extent possible.
- b. If wet walls or seepage above the base persists, then excavate and waterproof affected areas of the foundation see 30.50(6.).

### 4. Maintenance After Repair

- a. Keep downspouts extended.
- b. Maintain positive pitch of grade away from house.

### 5. No Site Specific Engineering required.

## (c.) Water Seepage through Floor Slab

1. Water seepage occurs through cracks in the floor slab, away from the basement wall, causing discoloration and dampness.

### 2. Testing

- a. Break open floor at site of seepage.
- b. Check for defective sump pump or stuck palmer valve (if present). Check with local jurisdiction if palmer valve is permitted (per local requirements).
- c. Check for interior drain tile presence and perform interior drain tile test. See Appendix A.

- d. Check sewer system for proper drainage.
3. Standard Repair
  - a. Remove floor along leak areas.
    - (1.) No Drain Tile
      - (a.) Dig out substrate, install drain tile and approved drainage system, embed in filtering stone, install sump crock and pump (if required) replace floor removed. See 30.50(6.).
    - (2.) Drain Tile Found
      - (a.) Replace as needed, interior drain tile to provide correct drainage to sump or palmer valve. See 30.50(7.).
    - (3.) If Leak Not Along Wall
      - (a.) Install additional interior drain tile lateral for drainage and connect to interior wall perimeter drain tile.
      - (b.) Install, replace, or repair sump pump. Sump pump must meet state and local Plumbing and Electrical Code.
      - (c.) Replace some or all of interior drain tile as necessary, drain first block into interior drain tile using an approved one-piece wall drainage board that provides water passage and lateral support to first course of block. Wall drainage board is to be 1" minimum higher than floor. Use a wall drainage board that can be caulked for retarding radon migration. Install to manufacturers specifications. See 30.50(6.) & Appendix A.
4. Maintenance After Repair See 30.50(4.)(a.)4.
5. No Site Specific Engineering required.

(d.) High Water Table

1. Significant amounts of water continuously flow into the sump crock or seepage occurs through cracks in the basement floor for extended periods of time, regardless of rain events or snow melts.
2. Possible conditions that may indicative of a high water table
  - a. Water enters a sump crock and overflows the crock while the pumps continue to operate normally due to lack of pump capacity.
  - b. There are ponds, streams, lakes or standing water in the vicinity of the house where the surface elevation of the water is higher than the drain tile elevation.
  - c. There is standing water in areas around the house during dry periods
  - d. The basement floor slab is deflected upward toward the center of the basement due to hydrostatic pressure.

3. Testing

- a. Soil borings and installation of monitoring wells at the property to determine the soil types and water table elevations
- b. Test pit excavation and analysis by a soils engineer to examine the soil for evidence of a seasonal high water table elevation
- c. Survey of the elevations of nearby bodies of water to compare to the elevation of basement floor.

- d. Research of municipal or other test wells in the vicinity that can be checked for water table levels.
  - e. Study of sources of storm water infiltration that may be affecting water table elevations.
4. Repairs: This condition requires Site Specific Engineering.
  5. Maintenance After Repair
    - a. Make sure sump pump discharges are free flowing.
    - b. Service backup battery and/or generator.
    - c. Rotate/replace sump pumps to prevent failure.
- (e.) Leaning or Bowed CMU Walls/Wall Deflection less than 1" (NO MOVEMENT)
1. One or more walls are bowed or leaning with no signs of current or recent movement. The total amount of wall deflection is less than one inch from the original wall construction. Water seepage may be present at the floor line. Cracks have been patched or tuck-pointed 10 years or more in the past\* with no sign of recent painting or patching. Owner indicates no observation of change in crack appearance or width. There may be evidence of prior wall repair/reinforcing or the walls could have been constructed out of plumb.
  2. Testing
    - a. Laser level, minimum six foot level or plumb line and tape measure to check wall for vertical alignment.
  3. Standard Repair
    - a. No repairs required; Advise owner to monitor for further movement.
  4. Optional Repairs
    - a. Reinforce with recommended engineered steel support restraints every 36 to 50" on center, along bowed or leaning wall without excavating, grout behind supports. See Wall Reinforcement Design and Details. See Appendix C.
    - b. Excavate; straighten as best as possible. Reinforce with recommended engineered steel beam restraints. Reseal wall. Clean out bleeders and test interior drain tile for correct flow, replace exterior drain tile, backfill to within 12-18" of grade with clear stone backfill. See 30.50(6.) & Appendix C.
    - c. Replace any defective interior drain tile to provide adequate drainage to sump or sewer system. See 30.50(7.) & Appendix A.
  5. Maintenance After Repair See 30.50(4.)(a.)4.
  6. No Site Specific Engineering Required.

\*Evidence of work performed 10 years or more prior to date of inspection include: past work orders, old paint-peeled or discolored, dated photographs, past inspections, other evidence of work performed prior to 10 years.

(f.) CMU Wall Step Cracks with No Movement

1. Appearance of cracks that follow the block joints in a diagonal fashion (step cracks). Many step cracks occur at the edge of windows or wall openings. There is no evidence of wall displacement, bowing or water seepage. Step cracks can be associated with minor foundation settlement or shrinkage of the concrete masonry

wall. Under this condition there are no continuous horizontal wall cracks, water seepage or displacement.

2. Testing See 30.50(4.)(e.)2.
  - a. Laser Level or transit to check for horizontal alignment.
3. Standard Repair
  - a. Tuck-point the visible cracks and recommend to owner to monitor for further movement.
  - b. If the crack exceeds  $\frac{1}{4}$ " width or there are indications of settlement, consult engineer for Site Specific Engineering.
4. Maintenance After Repair 30.50(4.)(a.)4.
5. No Site Specific Engineering Required.

(g.) Leaning or Bowed CMU Walls/ Wall Deflection less than 1" (Some Movement)

1. One or more walls are bowed or leaning, with signs of current or recent movement within the past 10 years. Wall cracks are less than  $\frac{1}{4}$ " wide. The total amount of wall deflection is less than one inch from the as-built condition of the original wall construction. Water seepage may be present at the floor line. Previously repaired wall cracks show signs of continued cracking. Horizontal wall cracks are usually associated with bowing and may open and close with the seasons. Vertical or step wall cracks are usually associated with leaning walls or wall bowing adjacent to wall irregularities. There is no indication of settlement of the wall footings.
2. Testing 30.50(4.)(e.)2.
3. Standard Repairs
  - a. Reinforce with recommended engineered steel support restraints every 36 to 50" on center, along bowed or leaning wall without excavating, grout behind supports. See Wall Reinforcement Design and Details. See Appendix C.
4. Optional Repairs
  - a. See 30.50(4.)(h.)4.a.
  - b. If bowing or leaning is in conjunction with wet walls or seepage, include previous repairs and testing. See 30.50(7.) & Appendix A.
5. Maintenance After Repair 30.50(4.)(a.)4.
6. No Site Specific Engineering Required

(h.) Leaning or Bowed CMU Walls/Wall Deflection 1" or More

1. One or more walls are bowed or leaning with signs of current or recent movement. Wall cracks may be greater than  $\frac{1}{4}$ " wide. The total amount of wall deflection is one inch or more from the as-built condition of the original wall construction. Water seepage may be present at the floor line. Previously repaired wall cracks show signs of continued cracking. Horizontal wall cracks are usually associated with bowing and may open and close with the seasons. Vertical or step wall cracks are usually associated with leaning walls or wall bowing adjacent to wall irregularities. There is no indication of settlement of the wall footings.
2. Testing 30.50(4.)(e.)2.
3. Standard Repair



- a. Excavate; straighten as best as possible. Reinforce with recommended engineered steel beam restraints. Reseal wall. Clean out *bleeders* and test interior *drain tile* for correct flow, replace exterior drain tile, *backfill* to within 12-18" of *grade* with clear *stone backfill*. See 30.50(6.) & Appendix C.
- 4. Optional Repair
  - a. Remove and replace wall with new concrete masonry or poured concrete constructed and reinforced per State of Wisconsin Uniform Dwelling Code requirements for construction of new basement walls. See SPS 321.18 (1).
- 5. Maintenance After Repair 30.50(4.)(a.)4.

(i.) CMU Walls Sheared at Base/Wall Slide Less than ½"

- 1. Wall shearing or sliding usually occurs at the second course from the bottom block. The bottom block is anchored by the floor. Shearing, however, may occur at any level. This condition indicates one section of the wall is sliding off the remaining wall by less than ½". There is no evidence of block face failure.
- 2. Testing 30.50(4.)(e.)2.
- 3. Standard Repairs See 30.50(4.)(g.)3.a.
- 4. Optional Repairs See 30.50(4.)(h.)4.a.
- 5. Maintenance After Repair 30.50(4.)(a.)4.

(j.) CMU Walls Sheared at Base/Wall Slide ½" or more

- 1. Wall shearing or sliding usually occurs at the second course from the bottom block. The bottom block is anchored by the floor. Shearing, however, may occur at any level. This condition indicates one section of the wall is sliding off the remaining wall by ½" or more. Excessive wall slide can cause failure in the block face below and potential basement wall collapse.
- 2. Testing 30.50(4.)(e.)2.
- 3. Standard Repairs See 30.50(4.)(h.)3.a.
- 4. Optional Repair See 30.50(4.)(g.)4.a.
- 5. Maintenance After Repair 30.50(4.)(a.)4.

(k.) Dropped, Settled or Rotated Footing Under CMU Wall

- 1. Foundation settlement is indicated by wide horizontal or step wall cracking and cracks in the floor slab, usually adjacent to the basement wall. The wall cracks are usually much wider than would be indicated by typical wall bowing. The wall may be tipped in the direction of foundation settlement, with horizontal wall joints being out of level. Door jams and windows in the building may be affected by foundation settlement.
- 2. Testing 30.50(4.)(e.)2.
  - a. Laser Level of transit to check for horizontal alignment.
- 3. Standard Repairs Requiring Site Specific Engineering
  - a. Repair may be accomplished with engineered helical pier anchors, hydraulically driven pipe piles, drilled caissons, support pads, etc. that are attached to the bottom of the footing.

4. Maintenance After Repair 30.50(4.)(a.)4.

(l.) Poured Concrete, Brick or Stone Walls with Water Seepage (No Movement)

1. Shrinkage of concrete or masonry often leads to cracks in basement walls. Poured concrete walls with little or no steel reinforcement are more susceptible to shrinkage cracking. During periods of heavy rains, water seepage can occur through cracks in the walls. Another cause of cracking in walls could be due to excessive pressure during backfilling or winter frost.
2. Testing 30.50(4.)(a.)2.
  - a. Check Palmer valve or sump pump for correct operation. Check with local jurisdiction if palmer valve is permitted (per local requirements)
  - b. Break open floor, test interior drain tile for correct flow. See Appendix A.
  - c. Use water spud pipe, inserted along outside wall to exterior drain tile, to introduce water to check exterior drain tile operation.
  - d. Check for proper grade away from exterior walls and adequate gutters & downspouts.
3. Standard Repairs
  - a. Inject cracks from inside without excavating. Inject per manufacturing specifications. (NON-STRUCTURAL REPAIR – polyurethane injection for water stoppage only)
  - b. In some cases, it may be necessary to excavate to footing, inject cracks or fill cracks with hydraulic cement, seal wall, clean out bleeders, replace exterior drain tile, backfill to within 12-18" of grade with clear stone backfill. See 30.50(6.) & 30.50(7.)
  - c. Refer to Condition #2 for additional standard repairs.
4. Maintenance After Repair 30.50(4.)(a.)4.

(m.) Poured Concrete walls, Leaning or bowed/wall deflection less than 1"

1. One or more walls are bowed or leaning, with signs of current or recent movement. Wall cracks are less than ¼" wide. The total amount of wall deflection is less than one inch from the original wall construction. Water seepage may be present at the floor line. Previously repaired wall cracks show signs of continued cracking. Horizontal wall cracks are usually associated with bowing and may open and close with seasons. Diagonal wall cracks or displacement at vertical cracks are usually associated with leaning walls or wall bowing adjacent to wall irregularities. Vertical cracks are usually associated with shrinkage of concrete. There is no indication of settlement of the wall footings.
2. Testing 30.50(4.)(e.)2.
3. Standard Repair
  - a. See 30.50(4.)(l.)3.a.
    - i. STRUCTURAL REPAIR – epoxy injection for wall repair and water stoppage.
  - b. If wall is leaning, secure top of wall to prevent further movement. Additional wall reinforcement is not required. See Appendix C for detail.

- c. If wall is bowed, reinforce with recommended engineered steel restraints. See 30.50(4.)(h.)3.a.
- d. If bowing or leaning is in conjunction with wet walls or seepage, refer to previous interior drain tile repairs and testing procedures. See 30.50(7.) & Appendix A.

4. Maintenance After Repair 30.50(4.)(a.)4.

(n.) Poured Concrete walls, Leaning or bowed/ Wall deflection 1" or more

1. One or more walls are bowed or leaning, with signs of current or recent movement. Wall cracks may be greater than ¼" wide. The total amount of wall deflection is less than one inch from the original wall construction. Water seepage may be present at the floor line. Previously repaired wall cracks show signs of continued cracking. Horizontal wall cracks are usually associated with bowing and may open and close with seasons. Diagonal wall cracks or displacement at vertical cracks are usually associated with leaning walls or wall bowing adjacent to wall irregularities. Vertical cracks are usually associated with shrinkage of concrete. There is no indication of settlement of the wall footings.
2. Testing 30.50(4.)(e.)2.
3. Standard Repairs
  - a. See 30.50(4.)(e.)4.b.
  - b. Inject cracks or seal cracks with hydraulic cement in accordance with manufacturer specifications or with non-structural polyurethane repair.
  - c. If bowing or leaning is in conjunction with floor seepage, refer to previous interior drain tile repairs and testing procedures. See 30.50(7.) & Appendix A.
4. Maintenance After Repair 30.50(4.)(a.)4.

(o.) Brick walls leaning or bowed/wall deflection less than 1"

1. One or more walls are bowed or leaning, with signs of current or recent movement. Wall cracks are less than ¼" wide. The total amount of wall deflection is less than one inch from the original wall construction. Water seepage may be present at the floor line. Previously repaired wall cracks show signs of continued cracking. Horizontal wall cracks are usually associated with bowing and may open and close with seasons. Vertical wall cracks are usually associated with leaning walls or wall bowing adjacent to wall irregularities. Brick is in good structural condition with no sign of excessive deterioration. There is no indication of settlement of the wall footings
2. Testing 30.50(4.)(e.)2.
3. Standard Repair
  - a. Reinforce with engineered steel support restraints up to 36" max. on center spacing along bowed or leaning wall without excavating, grout behind supports. See Wall Reinforcement and Design. See Appendix C.
4. Optional Repair
  - a. See 30.50(4.)(h.)4.a.

- b. Remove and replace brick wall with new concrete masonry constructed and reinforced per State of Wisconsin Uniform Dwelling Code requirements for construction of new basements walls.

5. Maintenance After Repair 30.50(4.)(a.)4.

(p.) Brick Walls Leaning or Bowed/ Wall Deflection 1" or more

1. One or more walls are bowed or leaning, with signs of current or recent movement. Wall cracks are less than 1/4" wide. The total amount of wall deflection is less than one inch from the original wall construction. Water seepage may be present at the floor line. Previously repaired wall cracks show signs of continued cracking. Horizontal wall cracks are usually associated with bowing and may open and close with seasons. Vertical wall cracks are usually associated with leaning walls or wall bowing adjacent to wall irregularities. Brick may be in poor structural condition with signs of excessive deterioration. There is no indication of settlement of the wall footings
2. Testing 30.50(4.)(e.)2.
3. Standard Repairs See 30.50(4.)(h.)4.a. similar
4. Maintenance After Repair 30.50(4.)(a.)4.

(5.) Site Specific Engineering

- (a.) Site Specific Engineering is required for any Reinforcement of Basement walls where conditions do not conform to the standards of this document.
- (b.) If Site Specific Engineering is required, a Site Specific Engineering Report is required to be submitted as part of the permit application for foundation repair (see example in Appendix B).
- (c.) Alternative repair methods requiring site specific engineering:
  1. Internal core filling with concrete and steel reinforcing bars.
  2. Installation of an exterior concrete grade beam.
  3. Retention anchors installed outside the foundation wall with wall plates secured to the inside of the wall.
  4. Construction of additional masonry pilasters on inside or outside of wall.
  5. Installation of a carbon fiber and epoxy reinforcing on inside or outside of wall.
  6. Any walls needing repair with height greater than 8'2".
  7. Any wall repair using adjustable braces used to move basement walls without excavation.
  8. Excavation, straightening, and reinforcing of brick walls with wall deflection of 1" or more.
  9. Any structural repair of stone foundation walls other than replacement with new walls constructed per State of Wisconsin Uniform Dwelling Code requirements for new construction SPS 321.18 (1).  
Any other methods or materials used for foundation repair not listed in these Standards.

- (d.) Site Specific Engineering is not required for any foundation repair product or method that has a Wisconsin Building Product Evaluation, WAFRP, and SEWRBI Approval (Per the conditions listed in the approval letter).
- (6.) Procedure for Wall Repair Including: Excavation, Waterproofing & Reinforcement
- (a.) Excavate a trench on the exterior wall from grade to the tip of the footing.
  - (b.) Haul all excavated clay to an approved landfill.
  - (c.) Attempt to flush out all bleeders found on exterior footing to sump pump or palmer valve system. Check with local jurisdiction if palmer valve is permitted (per local requirements).
  - (d.) Flush inside drain tile to sump pump or palmer valve, if applicable, on affected wall.
  - (e.) Set jacks on the inside of the excavated walls and straighten the walls to the original position, or as close as possible. (If required)
  - (f.) Identify structurally damaged concrete block solid with concrete block (exterior or interior). Replace block, or repair with approved epoxy material, or fill block solid with concrete grout.
  - (g.) Repair all mortar joint cracks on outside of wall with TYPE M masonry cement. Seal coat all excavated walls from the footing to grade with approved below-grade damp proofing material installed per manufacturer's specifications.
  - (h.) Replace all removed drain tile on excavated wall with "ADS" polypropylene/fiberglass drain tile and connect to existing bleeders found on footing.
  - (i.) Backfill trench with clear crushed aggregate per specification below to with 12 to 18 inches from finish grade at all grass/dirt areas.
    - 1. 100% of the aggregate shall pass a 1-inch sieve.
    - 2. 90%-100% of the aggregate shall pass a ¾" sieve.
    - 3. 0-55% of the aggregate shall pass a 3/8" sieve.
    - 4. 0-5% of the aggregate shall pass a #8 sieve.
  - (j.) Install a below grade geotextile filter fabric with minimum 6 oz. density on top of stone backfill at all grass/dirt areas to prevent dirt contamination of the clear stone due to water filtration to exterior drain tile.
  - (k.) Finish backfilling trench areas with impervious fill sloped as best as possible away from the foundation to within 6" of ground surface, place topsoil or landscaping material to match existing finish grade height. Finished grade should be pitched at a minimum slope of ½" per foot away from building for a minimum distance of 10'-0". It is recommended to maintain grade 6" below wood framing if possible. If proper grading is not possible, inform owner of condition & recommend proper landscaping with appropriate water control measures.
  - (l.) Reinforce all excavated walls with steel reinforcing columns. (see Appendix C regarding reinforcement for size, spacing, and attachment details) Grout between steel columns and wall with a non-shrink grout to account for wall irregularities and displacement. (If required)
  - (m.) Extend wall reinforcement beam 1 space in each direction beyond damaged section of wall. (If required)

- (n.) Tuck-point all interior mortar joint cracks on all walls that are repaired.
- (7.) Procedure for Interior Drain Tile Repair without Excavation (see also Appendix A regarding drain tile testing standards)
- (a.) Remove floor along wall area (12" to 18" wide) to be repaired to allow replacement of interior drain tile. NOTE: Depending on the exterior ground pressure against the wall, bracing of the bottom 1/3 of the wall may be required to prevent the first course from moving after the floor has been removed.
  - (b.) Remove existing drain tile and flush with water to sump crock or palmer valve. Check for correct drainage. Check with local jurisdiction if palmer valve is permitted (per local requirements).
  - (c.) Replace drain tile at floor removal area with 3" min interior diameter perforated corrugated polyethylene (or other State of Wisconsin Uniform Dwelling Code compliant) drain tile and encase new tile with clear 3/4" diameter filtering stone.
  - (d.) Drill one (3/4 to 1 inch) drainage hole into the bottom of first course per core, under floor line, for block drainage. Holes shall be cleared for proper drainage.
  - (e.) Wall drainage board shall be a one-piece unit. Wall drainage board to be installed at least 1" minimum higher than finish floor height and against first course to assure unrestricted passage of water flow. The wall drainage board MUST provide lateral support to first block. Wall drainage board must be able to be sealed off to provide radon mitigation if necessary.
  - (f.) Test wall drainage board: Drill holes at the third to fourth block above the footing and every 3 to 4 feet horizontally for the entire wall where possible. Flush wall with water by inserting hose into injection holes. Check for unobstructed flow to wall drainage board by observing water flow at the base of the wall.
  - (g.) Replace floor where removed. Minimum thickness not to be less than 2" thick or at least as thick as what was originally in place.
  - (h.) If floor is ramped, to obtain minimum floor thickness the original floor must be removed a distance of 24" from the basement wall.
  - (i.) If existing braces exist they can be left in place if they are anchored to the footing or slab.
  - (j.) Site specific engineering is required for conditions that vary from these standards.
- (8.) Wall Drainage Board Specification
1. Drainage Board Products may be used meeting the following specifications:
    - a. Manufactured as 1 piece construction vertical and horizontal
    - b. Minimum 8" horizontal leg with optional extension with no restriction of water flow
    - c. Designed to provide proper lateral support of 1st course from solid material and concrete in contact with the exterior wall
    - d. Minimum of 1" extension above finished floor
    - e. Maximum of 3/8" open joint along top of wall board for placement of sealant for radon mitigation

## Appendix A - Drain Tile Test Procedure

1. Conditions that may Warrant a Drain Tile Test
  - a) Seepage/seepage on floor
  - b) Wet/damp wall blocks near floor
  - c) Staining/efflorescence on wall blocks near floor
  - d) Iron ochre, tree roots, or mineral/calcium deposits in sump crock or at palmer valve.
  - e) Wetness around floor cracks.
  - f) Not all conditions shall warrant a drain tile test
2. Location, Size and Number of Test Holes
  - a) The foundation repair contractor or foundation consultant should open a minimum of 3 holes to test interior tiles
  - b) Each interior hole should be at least 12" x 12"
  - c) The ideal location of interior test holes should be:
    - d) In or near corners
    - e) At sites where home owner noted seepage
    - f) Directly under windows (location of bleeders)
  - g) The exterior drain tile test depth is recommended to be within 1-foot above the exterior drain tile. This test is also referred as an outside "spud test".
  - h) An outside drain tile test is warranted if blockage of outside drain tile is suspected to be clogged due to signs of seepage.
  - i) Test four feet from bleeder if location is known.
  - j) At least two tests with spud pipe are recommended per wall(s) in question.
3. Test Procedures
  1. Homeowner should remove personal property at all test site locations
  2. Open hole in floor, expose inside of drain tile
  3. Inspect drain tile to determine degree of obstruction if any
  4. Introduce water into hole to determine if it drains
  5. Insert running hose into drain tile in both directions if possible to point of blockage
  6. Clean out bleeders, if found
  7. Insert running hose in bleeders to determine disbursement to exterior tile
  8. Check functionality of palmer valve or sump crock
  9. Drill at least (1) hole in block, where floor is opened up at a wet area in question, on inside to check if wall is holding water.
4. Evaluation of Need for Repair
  1. Based upon test results foundation repair contractor or foundation consultant should consider:
    - a. Degree of blockage (less than 30% marginal, more than 50% serious)
    - b. Amount of water sitting in tile
    - c. Condition of drain tile itself
    - d. Actual water flow through inside tile
    - e. Seasonal conditions
    - f. Ground water levels at time
    - g. Special situations (ochre, roots, mineral deposits)

- h. History and pattern of seepage from homeowner, if available
- i. Water seepage out of blocks
- j. Spacing and placement of cement drain tile
- k. Material around drain tile
- l. If interior drain tile is found to not have blockage then an exterior spud test is optional.
- m. Due to the severity of the leak, an optional spud test may be recommended to test the outside tile.

5. Report to Homeowner

- 1. Drain tile evaluation requires rendering an opinion and reasonable minds may differ
- 2. Foundation repair contractor or foundation consultant shall report areas of blockage and specify what sections of drain tile need repair in writing with a diagram
- 3. Foundation repair contractor or foundation consultant shall not misrepresent condition of drain tile for purposes of persuading homeowners to purchase repairs
- 4. Foundation repair contractor or foundation consultant may give homeowner option of replacing more drain tile than is necessary after explaining present conditions

6. Repair of Hole

- 1. Remove debris, damaged tile and old stone
- 2. Replace drain tile in hole with 3" interior diameter perforated corrugated polyethylene drain tile (or Wisconsin Uniform Dwelling Code compliant)
- 3. Install approved drainage board on side of hole
- 4. Encase new tile with 3/4" diameter filtering stone
- 5. Close hole with new cement unless homeowner elects to leave open for further inspection
- 6. In the event homeowner elects to leave hole open, foundation repair contractor or foundation consultant shall warn homeowner of risk of injury and possible flooding
- 7. Maximum of 3/8" open joint along top of wall board for placement of sealant for radon mitigation





Appendix C  
Foundation Repair Details

**BASEMENT WALL REINFORCEMENT DESIGN TABLES**  
(Tables based on 90 PCF equivalent soil pressure)

<b>WALL HEIGHT* - UP TO 6'-10"</b>				
<b>STEEL SIZE, SPACING and BLOCK SIZE</b>	<b>SINGLE JOIST SIDE MOUNT</b>	<b>DOUBLE JOIST Or 2x8 min. nailed to side of joist.</b>	<b>SINGLE JOIST With SADDLE</b>	<b>TJI JOIST</b>
<b>4" X 2" X 1/4"</b> <b>36" Max. Spacing</b> <b>8", 10" or 12"</b>	(2) 1" Dia. Bolts See Details 2-5 on S2-A (4) 1/2" Dia. Bolts See Details 1-5 on S2-B	(2) 5/8" Dia. Bolts See Details 10-13 on S4-A	(2) 1/2" Dia. Bolts See Details 24-28 on S7	(2) 1" Dia. Bolts See Details 6-9 on S3-A
<b>5" X 2" X 3/16"</b> <b>50" Max. Spacing</b> <b>10" or 12"</b>	(4) 5/8" Dia. Bolts See Details 1-5 on S2-B	(2) 3/4" Dia. Bolts See Details 10-13 on S4-A (4) 1/2" Dia. Bolts See Details 12-15 on S4-B	(2) 5/8" Dia. Bolts See Details 24-28 on S7	(4) 5/8" Dia. Bolts See Details 9-11 on S3-B
<b>WALL HEIGHT* &gt; 6'-10" UP TO 7'-6"</b>				
<b>STEEL SIZE, SPACING and BLOCK SIZE</b>	<b>SINGLE JOIST SIDE MOUNT</b>	<b>DOUBLE JOIST Or 2x8 min. nailed to side of joist.</b>	<b>SINGLE JOIST With SADDLE</b>	<b>TJI JOIST</b>
<b>5" X 2" X 3/16"</b> <b>36" Max. Spacing</b> <b>8", 10", or 12"</b>	(2) 1" Dia. Bolts See Details 2-5 on S2-A (4) 1/2" Dia. Bolts See Details 1-5 on S2-B	(2) 5/8" Dia. Bolts See Details 10-13 on S4-A	(2) 5/8" Dia. Bolts See Details 24-28 on S7	(2) 1" Dia. Bolts See Details 6-9 on S3-A
<b>6" X 2" X 3/16"</b> <b>or 5" X 3" X 1/4"</b> <b>50" Max. Spacing</b> <b>10", or 12"</b>	(4) 3/4" Dia. Bolts See Details 1-5 on S2-B	(2) 1" Dia. Bolts See Details 10-13 on S4-A (4) 1/2" Dia. Bolts See Details 12-15 on S4-B	(2) 3/4" Dia. Bolts See Details 24-28 on S7	(4) 3/4" Dia. Bolts See Details 9-11 on S3-B
<b>WALL HEIGHT* &gt; 7'-6" UP TO 8'-2"</b>				
<b>STEEL SIZE, SPACING and BLOCK SIZE</b>	<b>SINGLE JOIST SIDE MOUNT</b>	<b>DOUBLE JOIST Or 2x8 min. nailed to side of joist.</b>	<b>SINGLE JOIST With SADDLE</b>	<b>TJI JOIST</b>
<b>5" X 3" X 1/4"</b> <b>36" Max. Spacing</b> <b>8", 10", or 12"</b>	(4) 5/8" Dia. Bolts See Details 1-5 on S2-B	(2) 3/4" Dia. Bolts See Details 10-13 on S4-A (4) 1/2" Dia. Bolts See Details 12-15 on S4-B	(2) 5/8" Dia. Bolts See Details 24-28 on S7	(4) 5/8" Dia. Bolts See Details 9-11 on S3-B
<b>6" X 3" X 1/4"</b> <b>50" Max. Spacing</b> <b>10", or 12"</b>	(4) 7/8" Dia. Bolts See Details 1-5 on S2-B	(2) 1" Dia. Bolts See Details 10-13 on S4-A (4) 5/8" Dia. Bolts See Details 12-15 on S4-B	(2) 1" Dia. Bolts See Details 24-28 on S7	(4) 7/8" Dia. Bolts See Details 9-11 on S3-B

\*Wall Height is top of floor to bottom of joist (Field measurements can be rounded to the nearest 1/2")

\*\*Bottom Anchors : Min. (2) 5/8" dia. x 7" long expansion bolts into footing

Or (2) 3/4" dia. x 4" long expansion bolts min. 3" into slab

See Pages S5 thru S12 for Additional Connection and Wall reinforcing Details

**SPECIFICATIONS:**

STEEL TUBE WALL REINFORCING @ MAX. 36" O.C. MAY BE USED FOR 8", 10", OR 12" BLOCK WALLS AND MAX. 50" O.C. FOR 10" OR 12" BLOCK WALLS.

REINFORCING SPACING CAN BE THE AVERAGE OF TWO ADJACENT SPACES WITH A MAXIMUM SPACING OF 50" (10" OR 12" BLOCK). FOR EXAMPLE  $(4'-0" + 1'-4")/2 = 2'-8"$  AVERAGE SPACING, BUT IN NO INSTANCE CAN A SPACING EXCEED 50".

STEEL TUBE MUST HAVE MINIMUM 46KSI YIELD STRENGTH.

STEEL PLATE MUST HAVE 36KSI MINIMUM YIELD STRENGTH.

WELDING TO BE PER ASTM STANDARDS.

PRESTRESSING TUBES REQUIRES SITE SPECIFIC ENGINEERING.

REINFORCING GUIDELINES ALSO APPLY TO POURED CONCRETE, BRICK AND STONE WALLS OF EQUIVALENT HEIGHT AND THICKNESS.

BOLTS AND SLEEVES TO BE ZINC PLATED CARBON STEEL OR BETTER.

NEW WOOD BLOCKING TO BE DOUG. FIR NO.2 OR BETTER.

SCREW TYPE ANCHORS CAN BE USED IN LIEU OF EXPANSION BOLTS IN ALL CASES.

ALL STRUCTURAL CALCULATIONS FOR WOOD MEMBERS PER 2015 NATIONAL DESIGN SPECIFICATIONS FOR WOOD CONSTRUCTION (NDS).

IF PROPER GRADING IS NOT POSSIBLE, INFORM OWNER OF CONDITION & RECOMMEND PROPER LANDSCAPING WITH APPROPRIATE WATER CONTROL MEASURES.

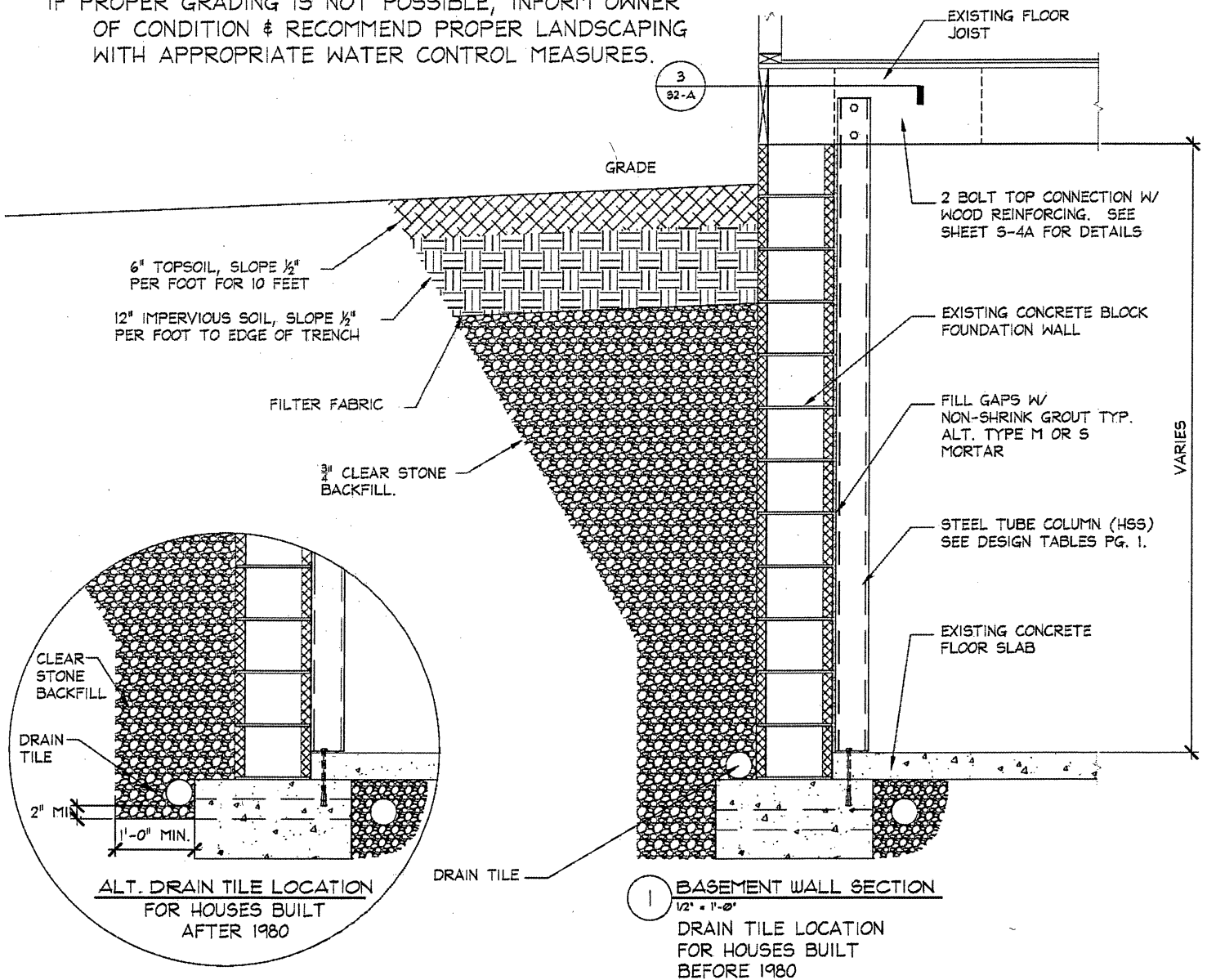

**TITLE: 2 Bolt Basement Wall Reinforcing Details**

SHEET: S1-A, Appendix C

DRAWN: JFJ

DATE: 3/26/03

REVISION: 07/12/17

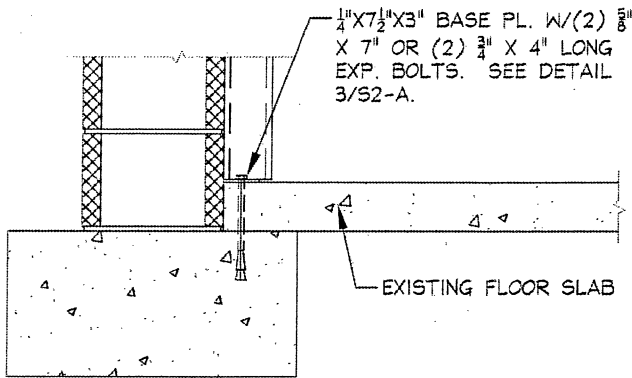
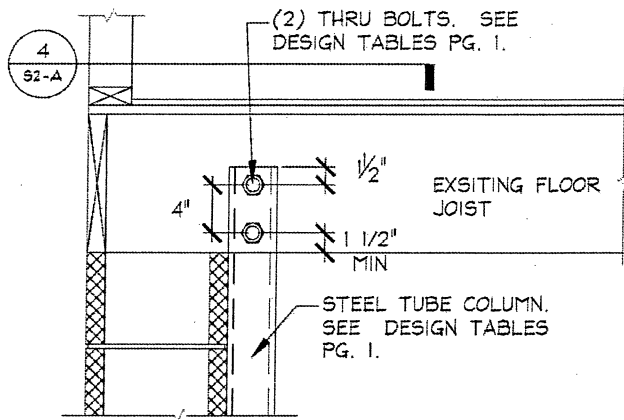

**2 CONNECTION DETAIL SIDE VIEW**  
3/4" = 1'-0"

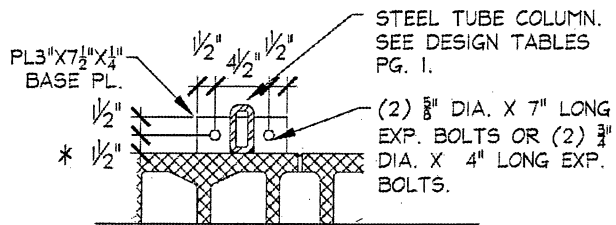
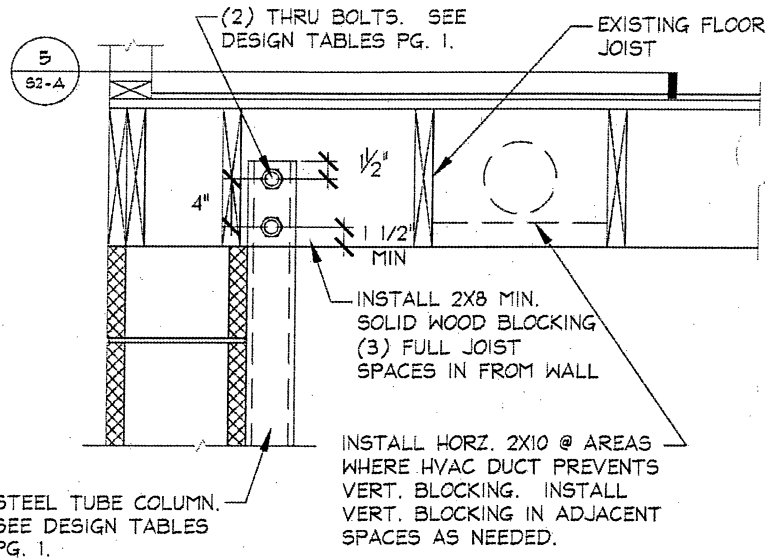

NOTE: 5/8" DIA. BOLTS HAVE A FACTOR OF SAFETY OF 3 IN-SOME CASES.

**3 BOTTOM CONN. DETAIL**  
3/4" = 1'-0"

\*BOLTS CAN BE OFFSET W/ 1 1/4" MIN. DIMENSION FROM FACE OF BLOCK WALL

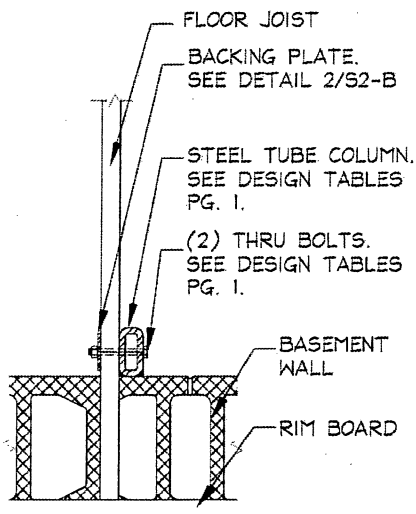

**4 TOP CONNECTION DETAIL**  
3/4" = 1'-0"

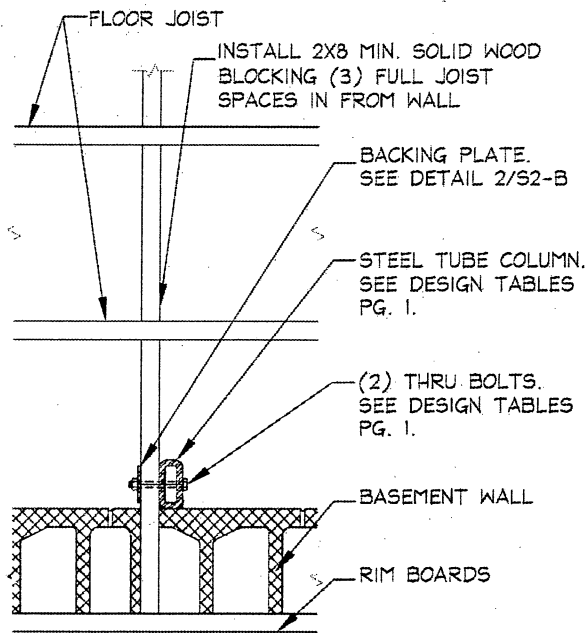

**5 TOP CONNECTION DETAIL**  
3/4" = 1'-0"

TITLE: 2 Bolt Top & Bottom Connection Details

SHEET: S2-A, Appendix C

DRAWN: JFJ

DATE: 3/26/03

REVISION: 07/12/17

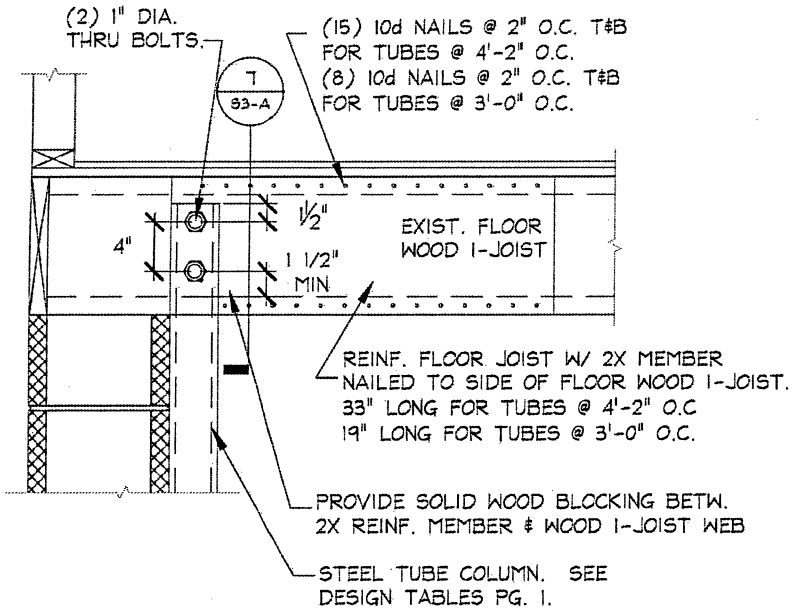

6 TJI CONNECTION DETAIL SIDE VIEW  
3/4" = 1'-0"

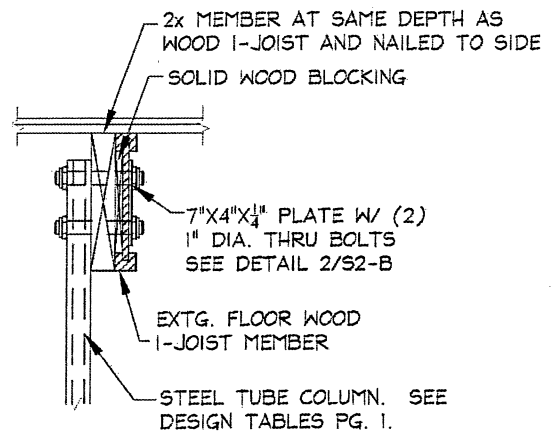

7 TJI CONNECTION DETAIL SECTION  
3/4" = 1'-0"

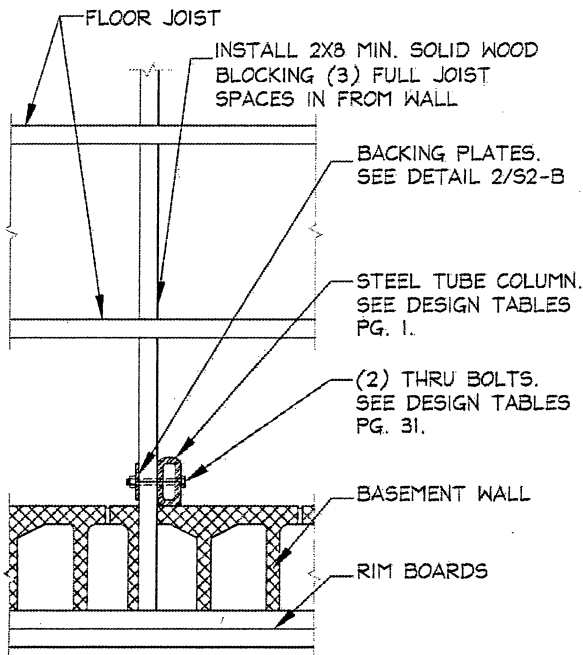

8 TOP CONNECTION DETAIL  
3/4" = 1'-0"

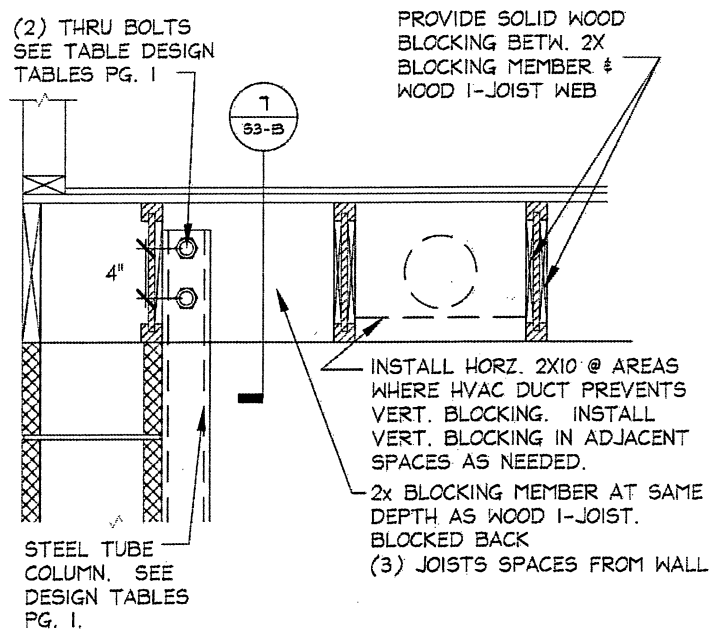

9 TOP CONNECTION DETAIL  
3/4" = 1'-0"

TITLE: 2 Bolt Wood I-Joist Top ConnectionDetails

SHEET: S3-A, Appendix C

DRAWN: JFJ

DATE: 3/26/03

REVISION: 07/12/17

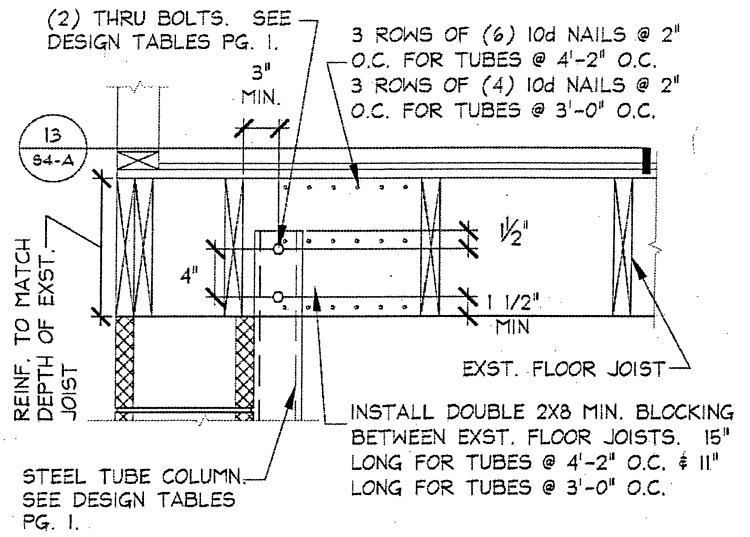
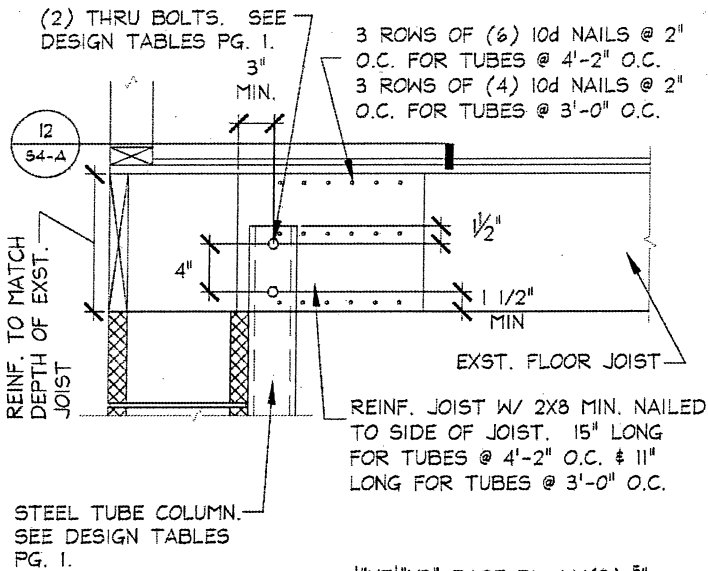

11 CONNECTION DETAIL SIDE VIEW  
3/4" = 1'-0"

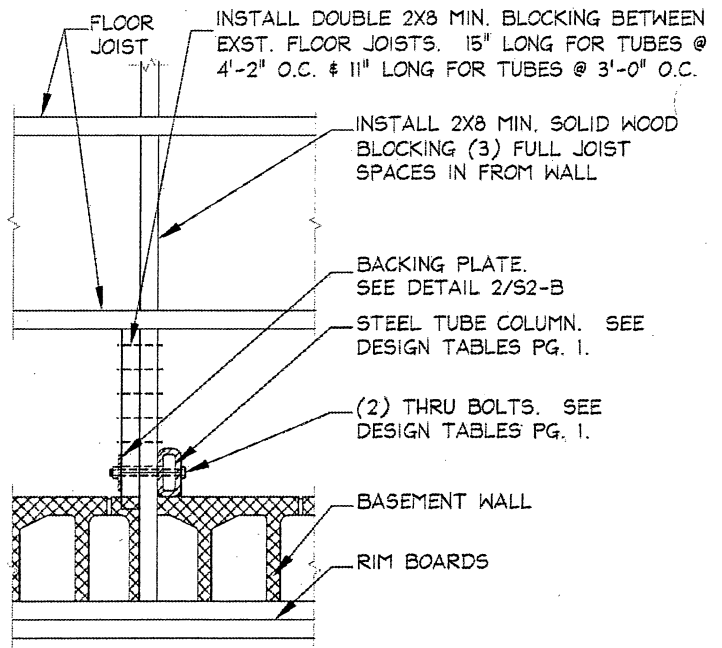
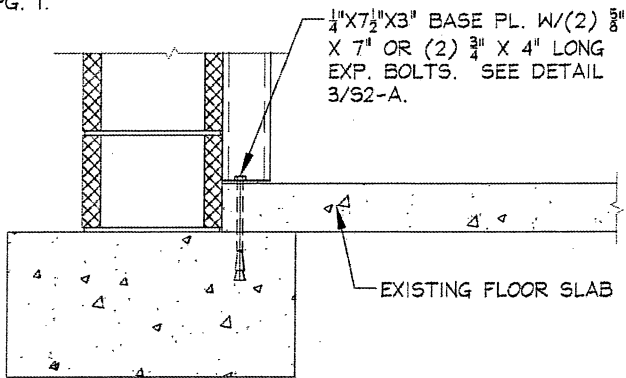

10 CONNECTION DETAIL SIDE VIEW  
3/4" = 1'-0"

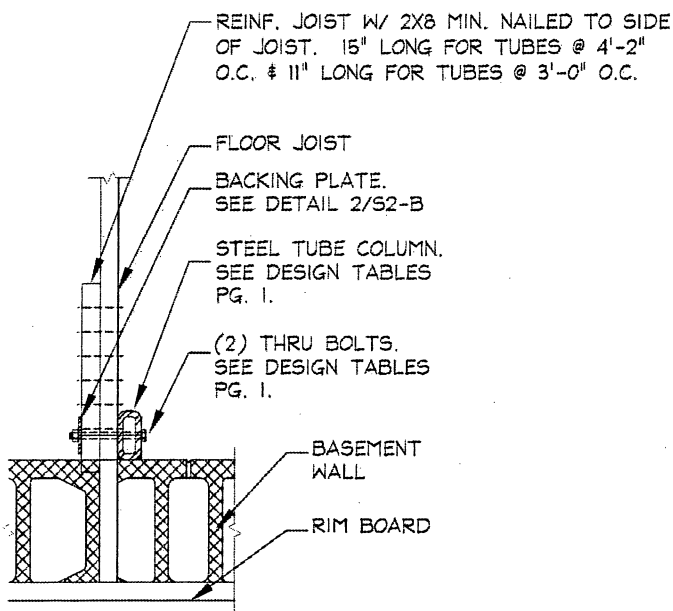

TITLE: 2 Bolt Top Connection W/Double Wood Joist	
SHEET: S4-A, Appendix C	DRAWN: JFJ
DATE: 3/26/03	REVISION: 07/12/17

**SPECIFICATIONS:**

STEEL TUBE WALL REINFORCING @ MAX. 36" O.C. MAY BE USED FOR 8", 10", OR 12" BLOCK WALLS AND MAX. 50" O.C. FOR 10" OR 12" BLOCK WALLS.

REINFORCING SPACING CAN BE THE AVERAGE OF TWO ADJACENT SPACES WITH A MAXIMUM SPACING OF 50" (10" OR 12" BLOCK). FOR EXAMPLE  $(4'-0" + 1'-4")/2 = 2'-8"$  AVERAGE SPACING, BUT IN NO INSTANCE CAN A SPACING EXCEED 50".

STEEL TUBE MUST HAVE MINIMUM 46KSI YIELD STRENGTH.

STEEL PLATE MUST HAVE 36KSI MINIMUM YIELD STRENGTH.

WELDING TO BE PER ASTM STANDARDS.

PRESTRESSING TUBES REQUIRES SITE SPECIFIC ENGINEERING.

REINFORCING GUIDELINES ALSO APPLY TO POURED CONCRETE, BRICK AND STONE WALLS OF EQUIVALENT HEIGHT AND THICKNESS.

BOLTS AND SLEEVES TO BE ZINC PLATED CARBON STEEL OR BETTER.

NEW WOOD BLOCKING TO BE DOUG. FIR NO.2 OR BETTER.

SCREW TYPE ANCHORS CAN BE USED IN LIEU OF EXPANSION BOLTS IN ALL CASES.

ALL STRUCTURAL CALCULATIONS FOR WOOD MEMBERS PER 2015 NATIONAL DESIGN SPECIFICATIONS FOR WOOD CONSTRUCTION (NDS).

IF PROPER GRADING IS NOT POSSIBLE, INFORM OWNER OF CONDITION & RECOMMEND PROPER LANDSCAPING WITH APPROPRIATE WATER CONTROL MEASURES.

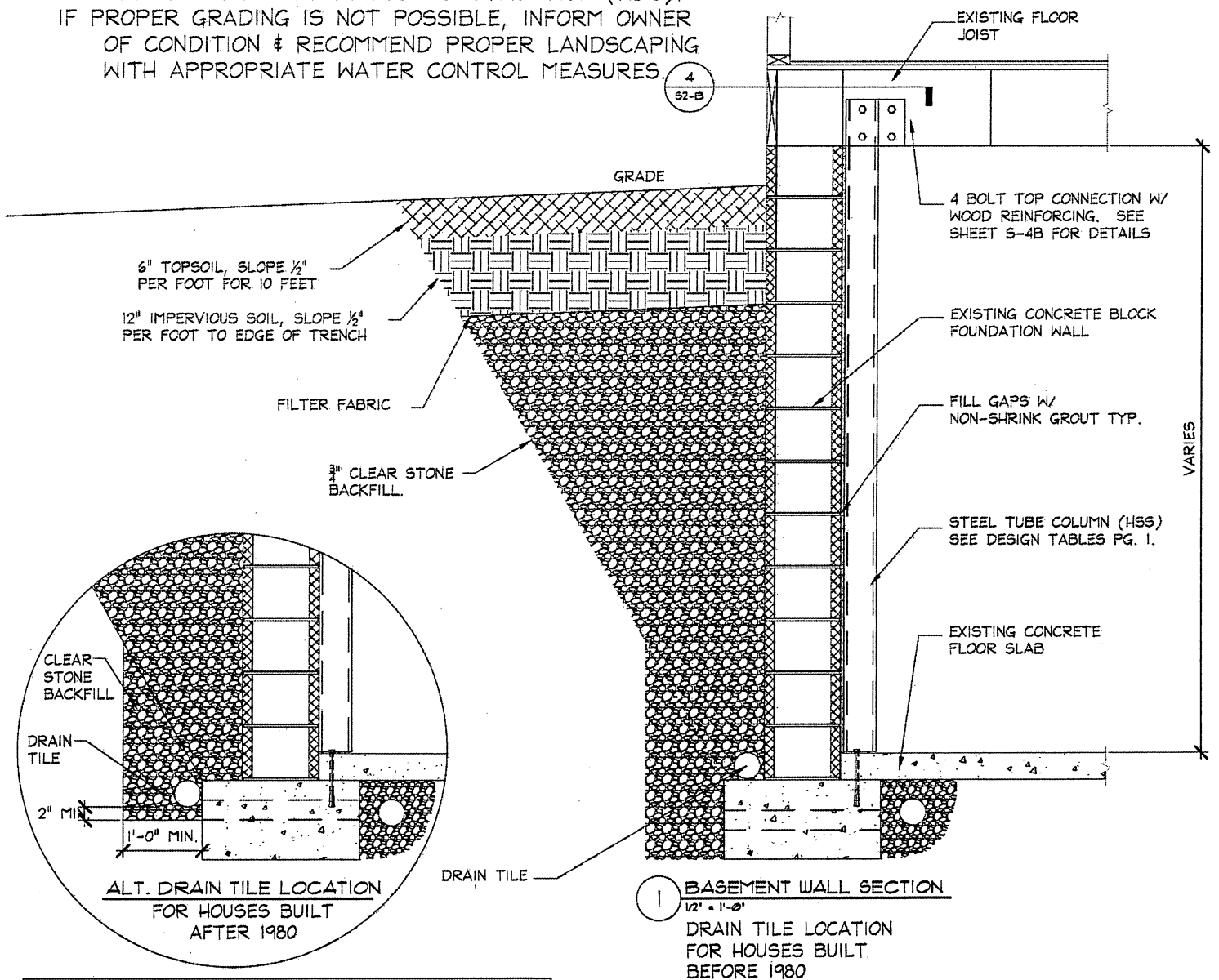

<b>TITLE: 4 Bolt Basement Wall Reinforcing Details</b>	
SHEET: S1-B, Appendix C	DRAWN: JFJ
DATE: 3/26/03	REVISION: 07/12/17

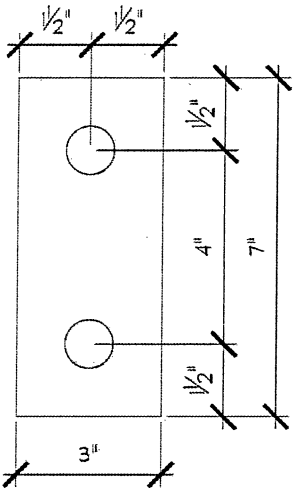
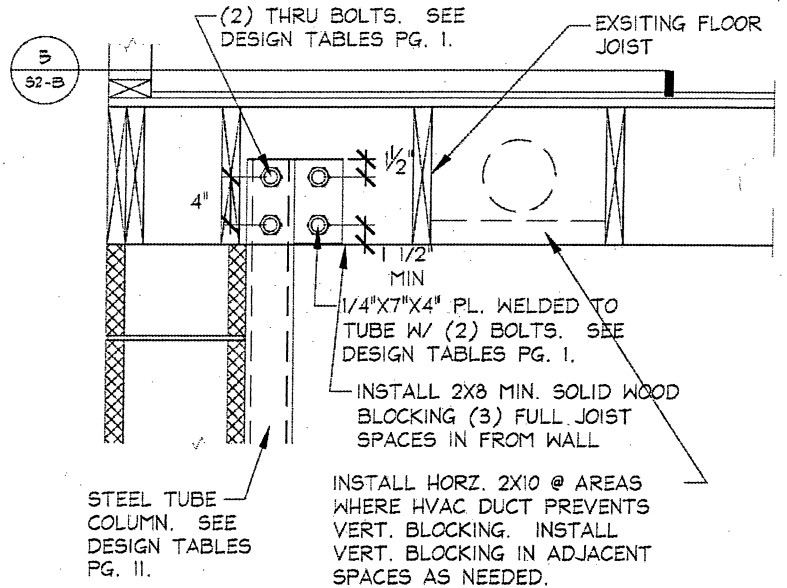
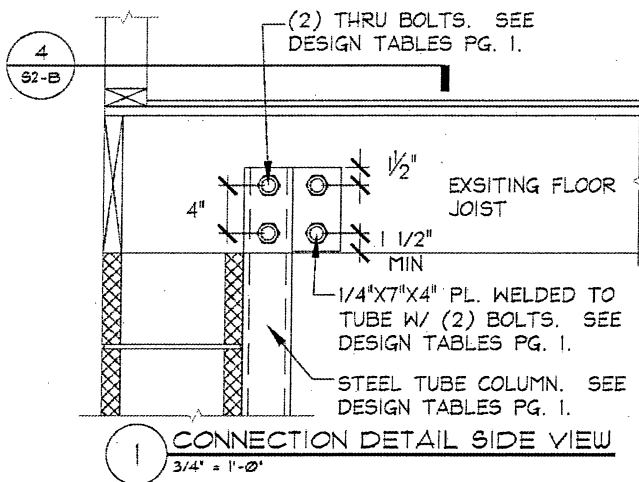

- ALTERNATES :
- 1 - (2) 1/8" THICK x 2" DIA. WASHERS CAN BE USED IN LIEU OF BACKING PLATE
  - 2 - 2" x 5" x 1/4" PL.
  - 3 - 3" x 7" x 1/4" PL. W/ VERTICALLY SLOTTED HOLES AND WASHERS.
- \* CRITICAL DIMENSION IS 4" BETWEEN BOLTS.

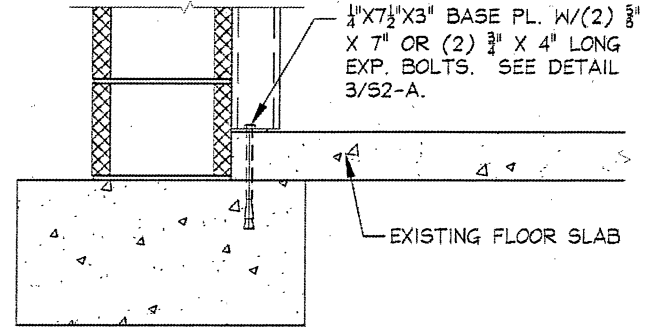

2 TOP PLATE DETAIL/BACKING PLATE

3" = 1'-0"

3 CONNECTION DETAIL SIDE VIEW

3/4" = 1'-0"

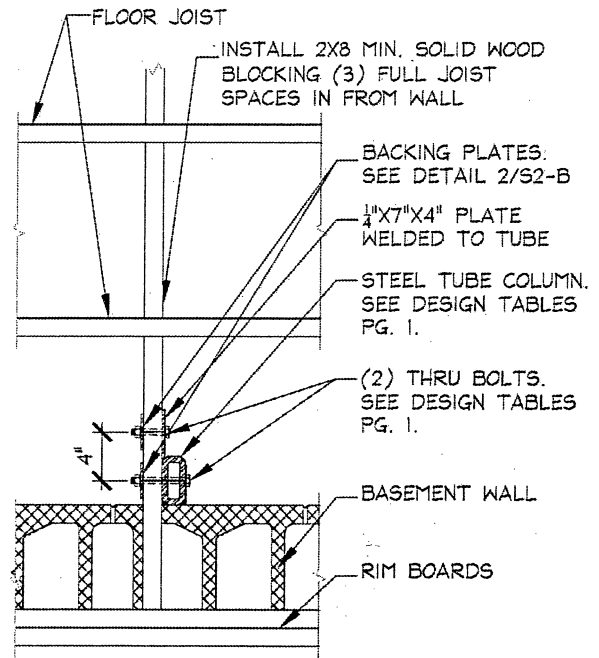
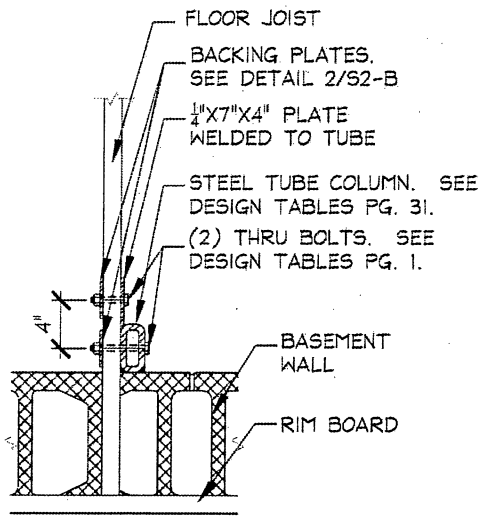

4 TOP CONNECTION DETAIL

3/4" = 1'-0"

5 TOP CONNECTION DETAIL

3/4" = 1'-0"

TITLE: 4 Bolt Top & Bottom Connection Details	
SHEET: S2-B, Appendix C	DRAWN: JFJ
DATE: 3/26/03	REVISION: 07/12/17



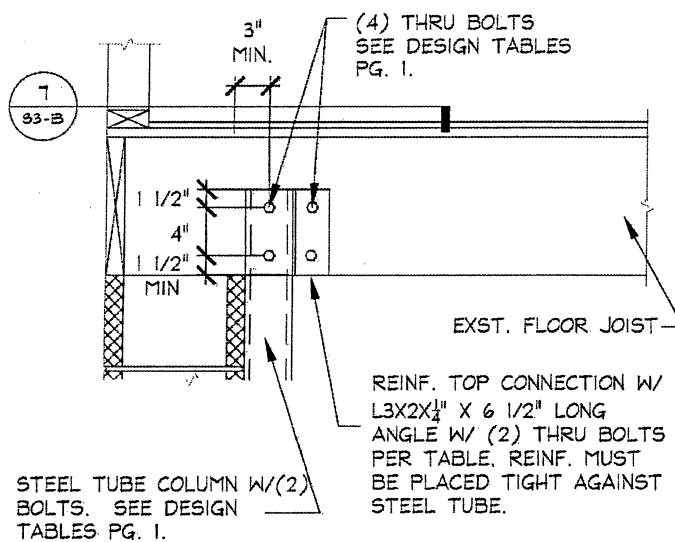

**6 STEEL ANGLE SUPPORT DETAIL SIDE VIEW**  
3/4" = 1'-0"

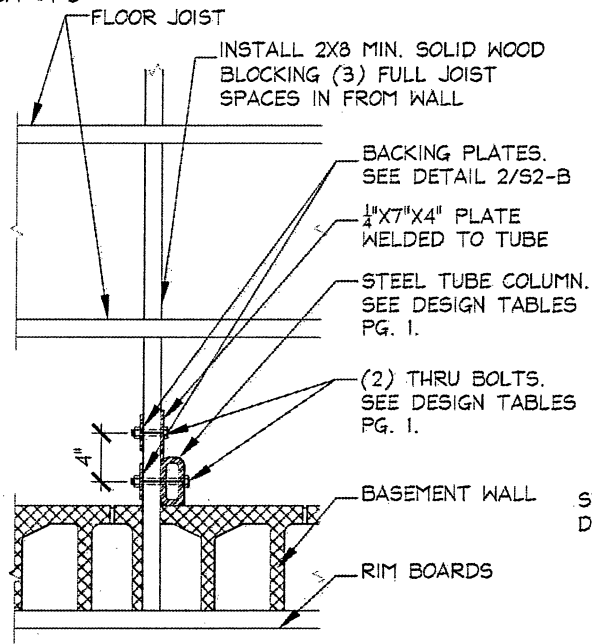

**8 TOP CONNECTION DETAIL**  
3/4" = 1'-0"

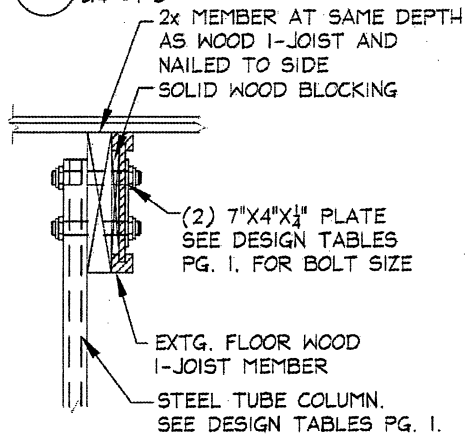

**10 TJI CONNECTION DETAIL SECTION**  
3/4" = 1'-0"

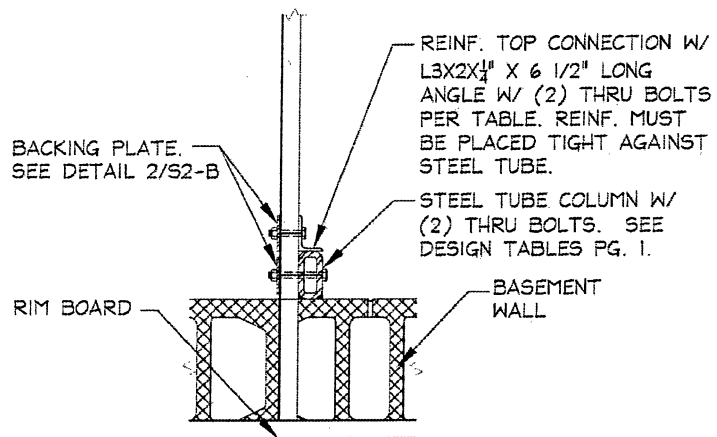

**7 STEEL ANGLE SUPPORT DETAIL**  
3/4" = 1'-0"

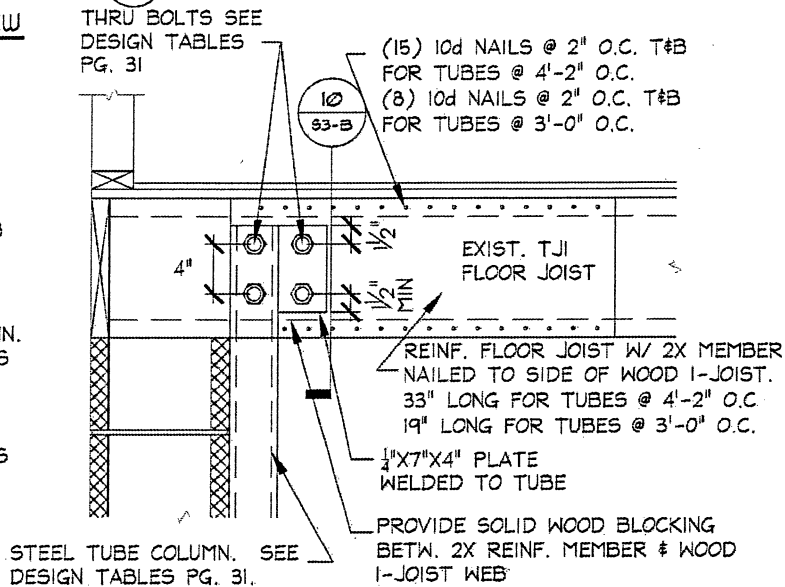

**9 TJI CONNECTION DETAIL SIDE VIEW**  
3/4" = 1'-0"

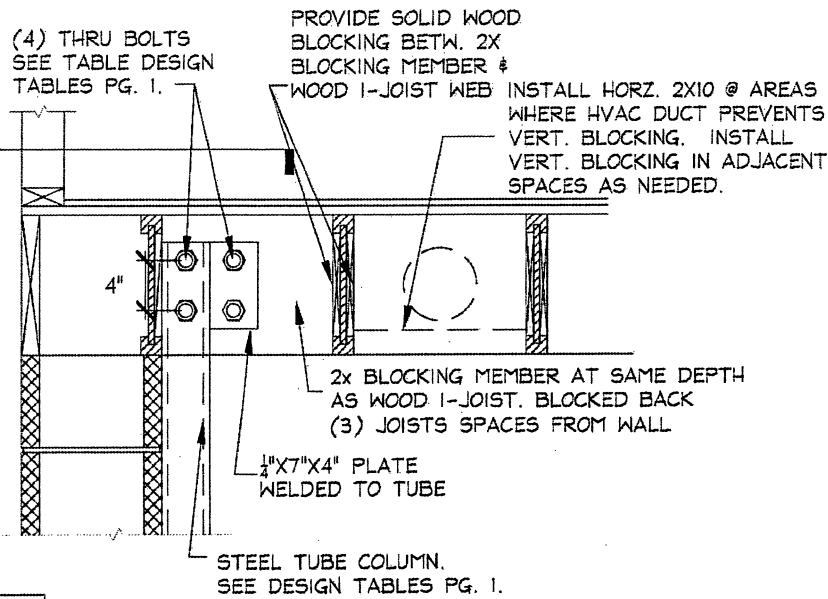

**11 TOP CONNECTION DETAIL**  
3/4" = 1'-0"

<b>TITLE: 4 Bolt Angle Connection &amp; Wood I-Joist Details</b>	
SHEET: S3-B, Appendix C	DRAWN: JFJ
DATE: 3/26/03	REVISION: 07/12/17

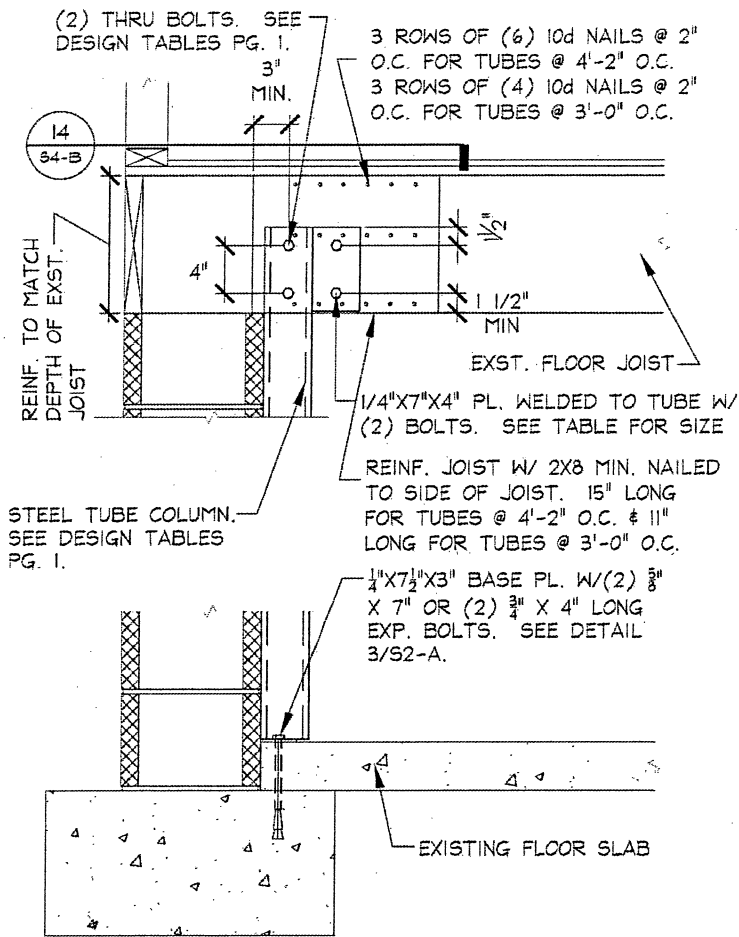

12 CONNECTION DETAIL SIDE VIEW  
3/4" = 1'-0"

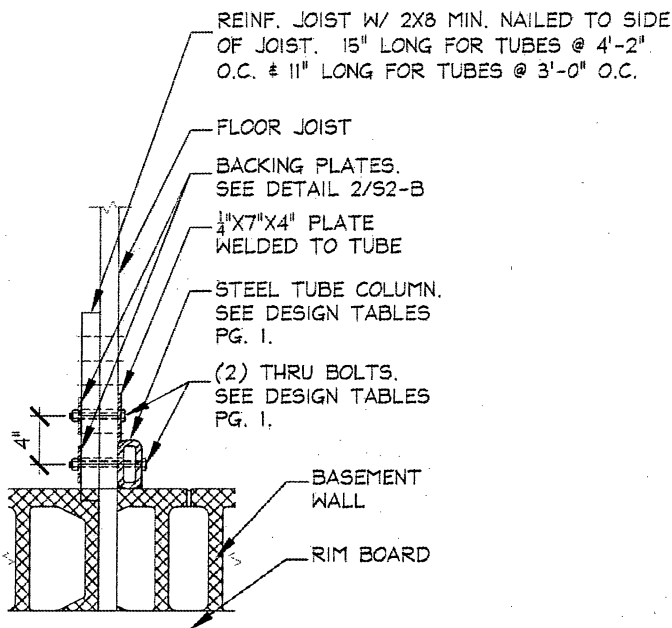

14 TOP CONNECTION DETAIL  
3/4" = 1'-0"

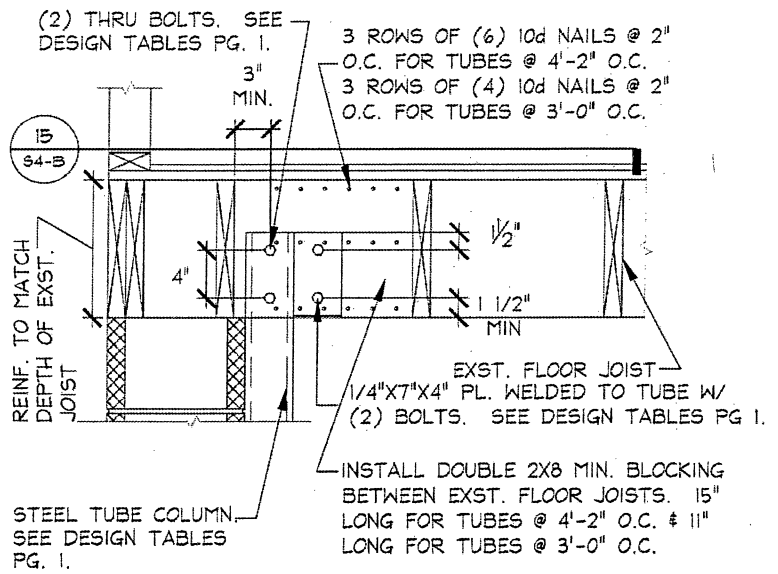

13 CONNECTION DETAIL SIDE VIEW  
3/4" = 1'-0"

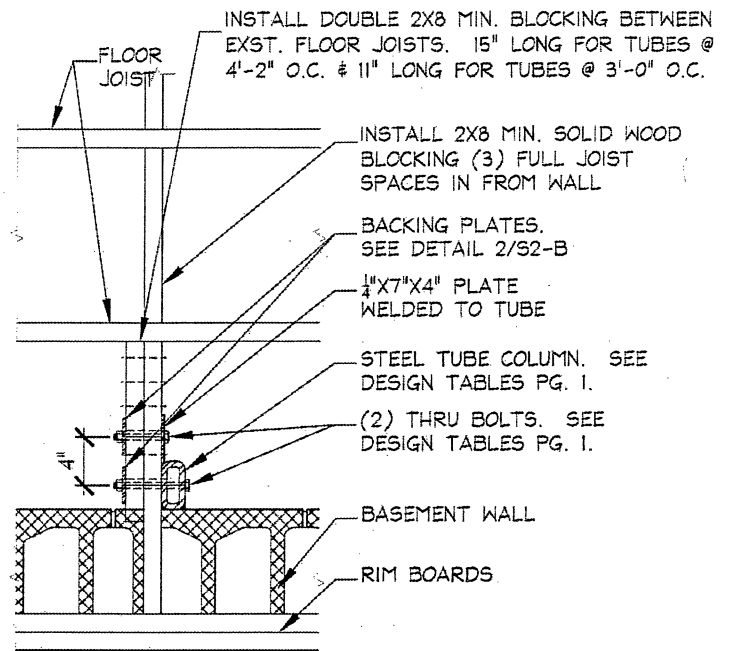

15 TOP CONNECTION DETAIL  
3/4" = 1'-0"

TITLE: 4 Bolt Top Connec W/Double Wood Joist	
SHEET: S4-B, Appendix C	DRAWN: JFJ
DATE: 3/26/03	REVISION: 07/12/17

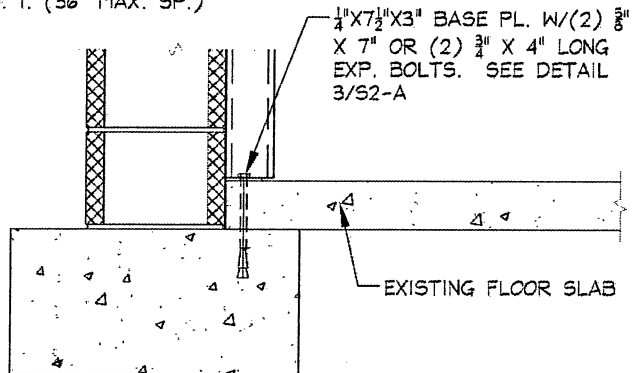
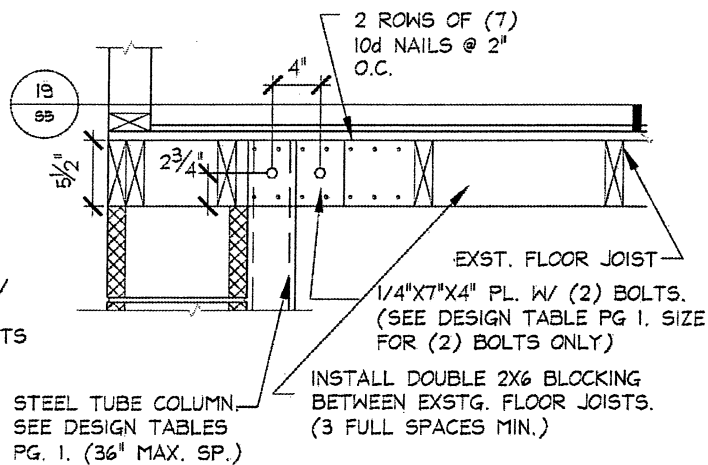
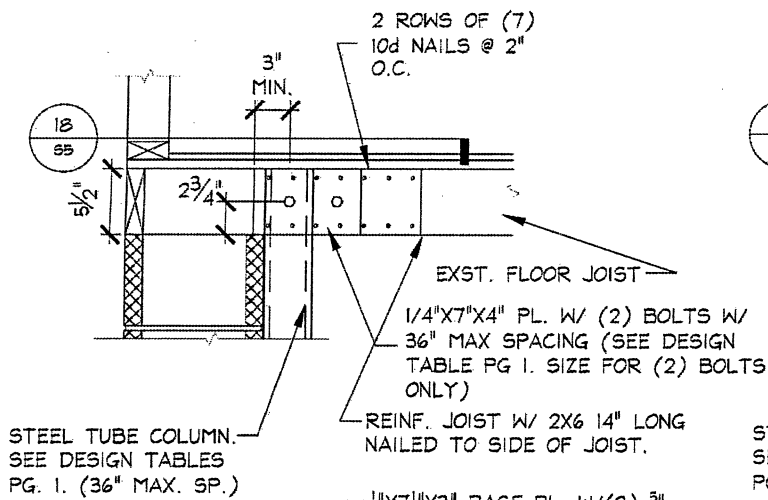

16 CONNECTION DETAIL SIDE VIEW  
3/4" = 1'-0"

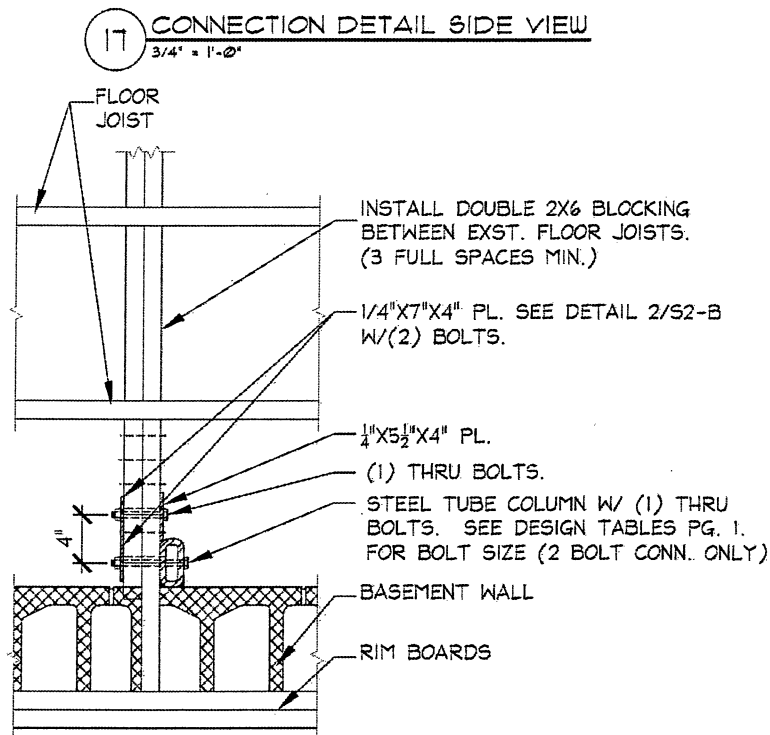

19 TOP CONNECTION DETAIL  
3/4" = 1'-0"

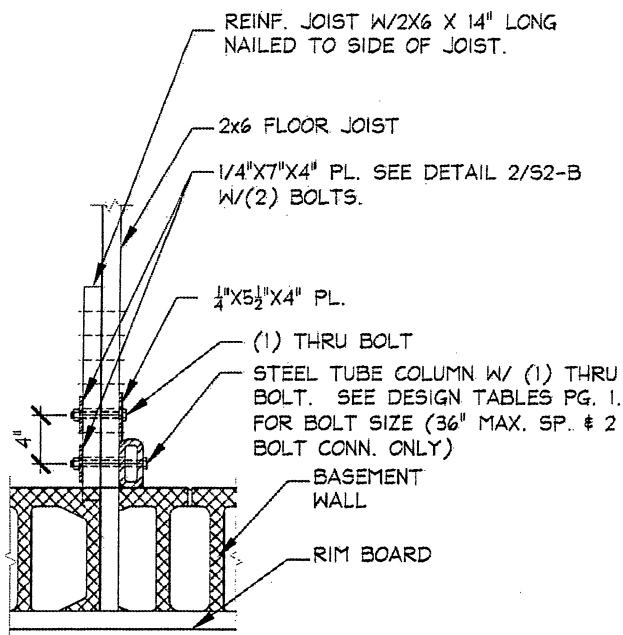

18 TOP CONNECTION DETAIL  
3/4" = 1'-0"

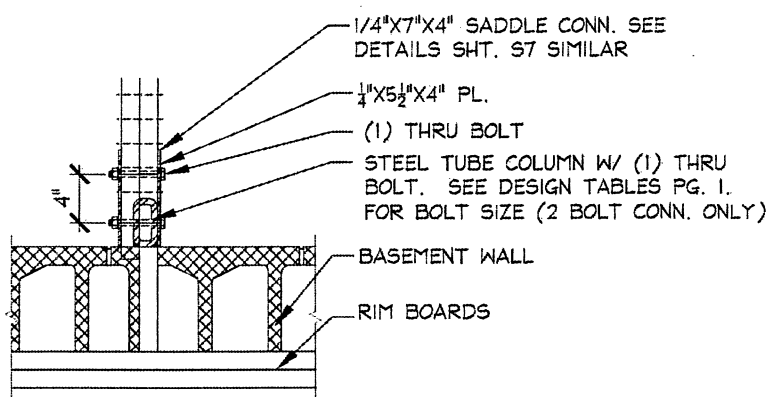

ALT. TOP CONNECTION DETAIL  
3/4" = 1'-0"

TITLE: 2x6 Connection Details

SHEET: S5, Appendix C

DRAWN: JFJ

DATE: 06/15/10

REVISION: 07/12/17

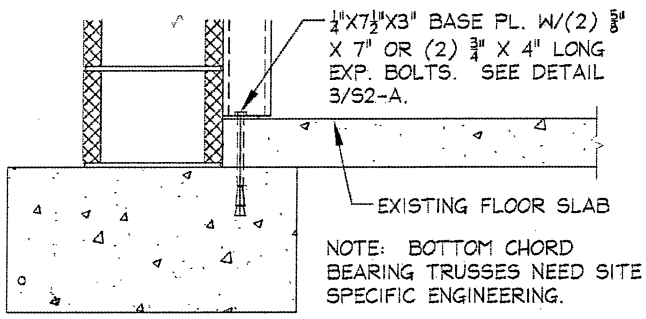
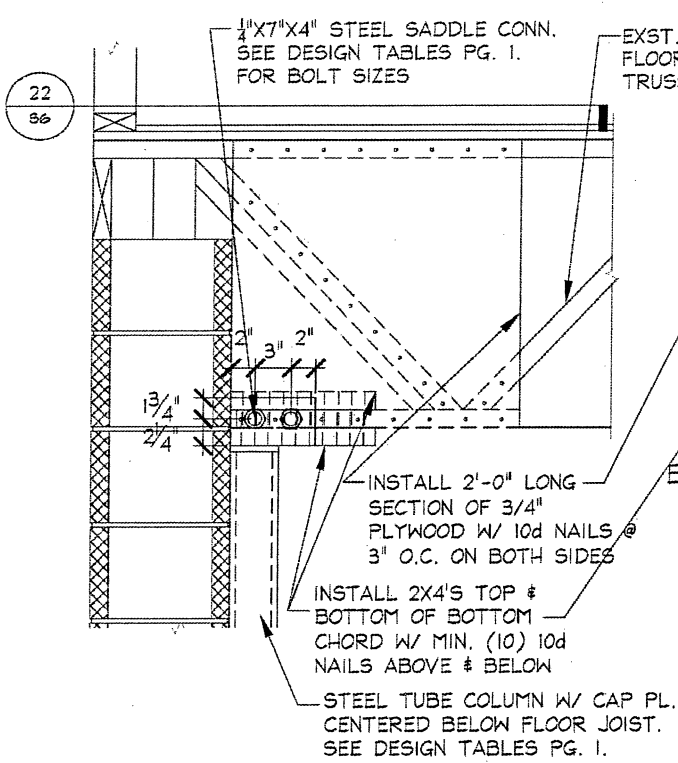

20 CONNECTION DETAIL SIDE VIEW  
3/4" = 1'-0"

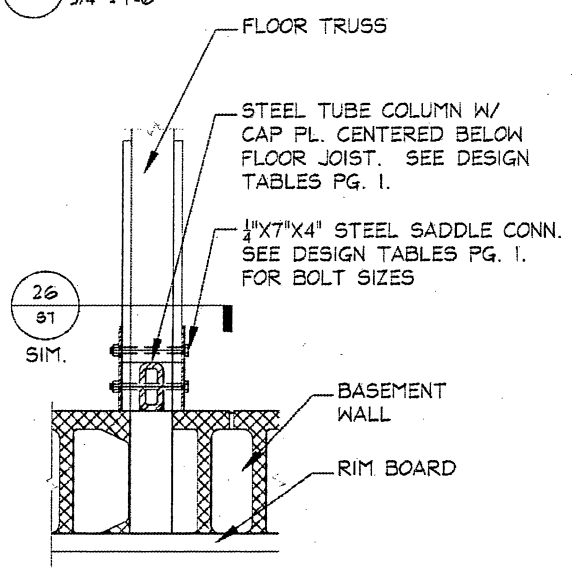

22 TOP CONNECTION DETAIL  
3/4" = 1'-0"

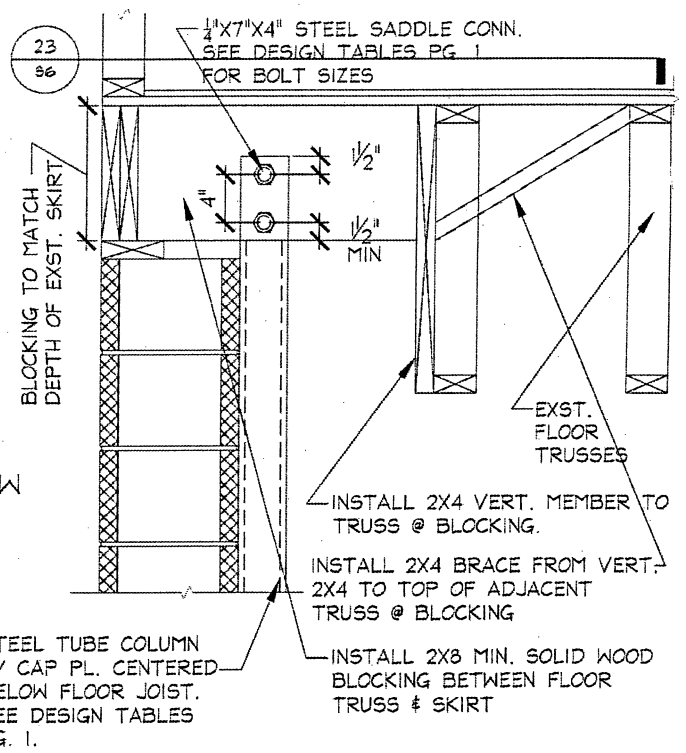

21 CONNECTION DETAIL SIDE VIEW  
3/4" = 1'-0"

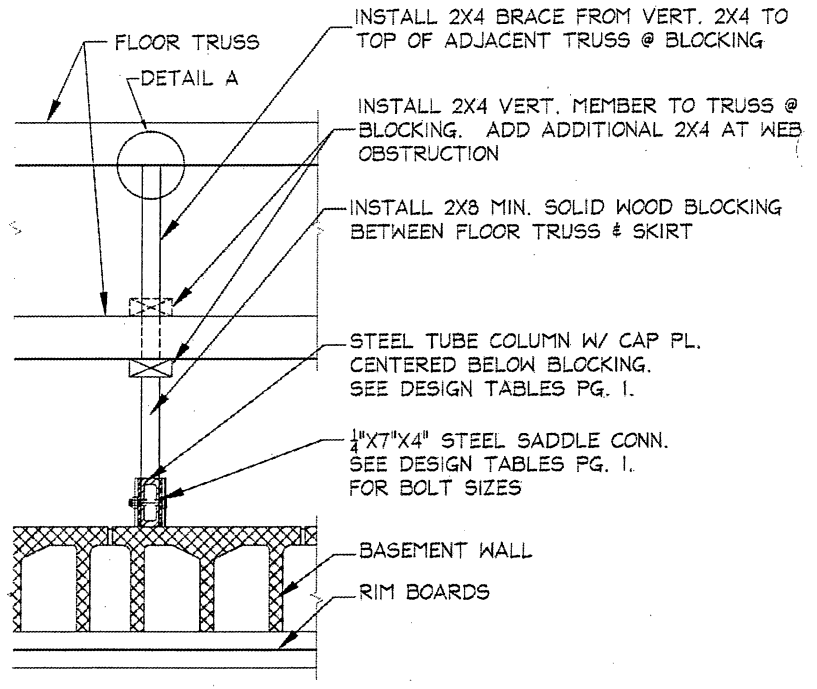

23 TOP CONNECTION DETAIL  
3/4" = 1'-0"

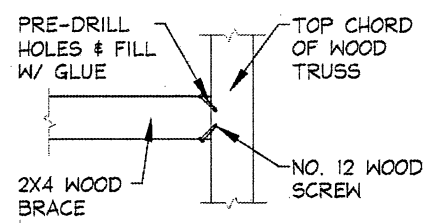

A TOP VIEW  
1" = 1'-0"

TITLE: <b>Top Connection W/Floor Trusses</b>	
SHEET: S6, Appendix C	DRAWN: JFJ
DATE: 3/26/03	REVISION: 07/12/17

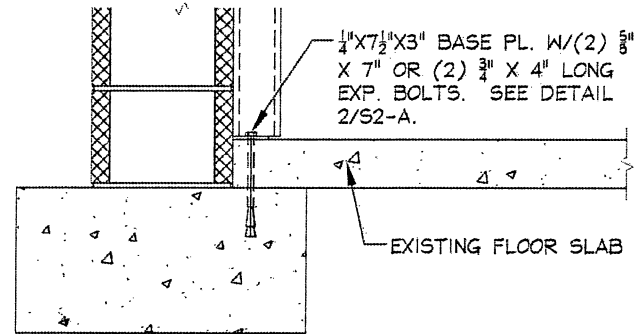
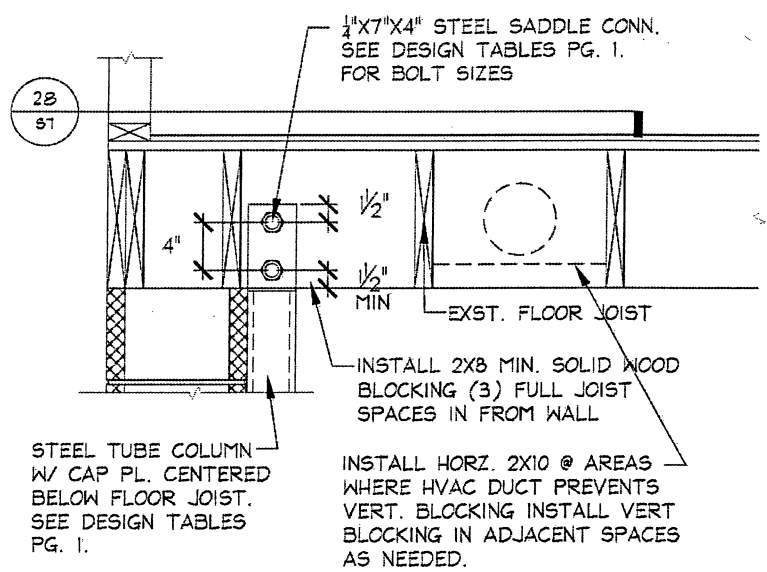
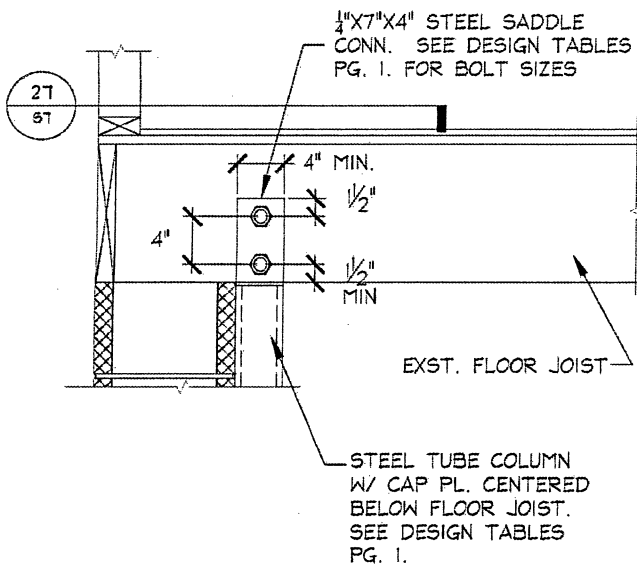

25 CONNECTION DETAIL SIDE VIEW  
3/4" = 1'-0"

24 CONNECTION DETAIL SIDE VIEW  
3/4" = 1'-0"

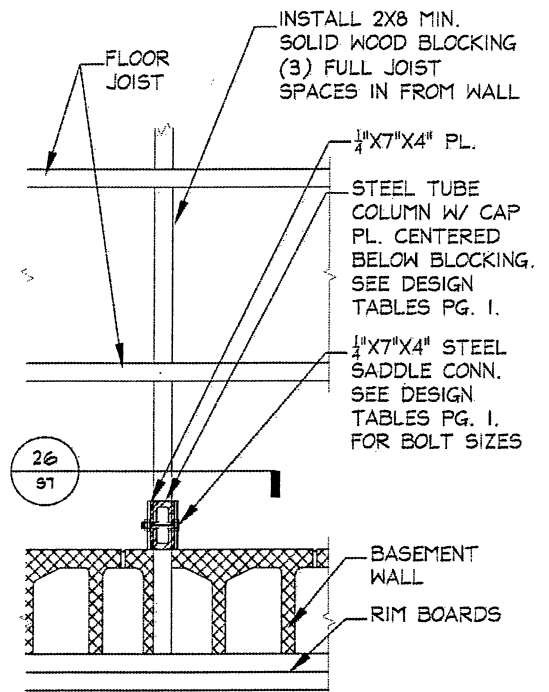
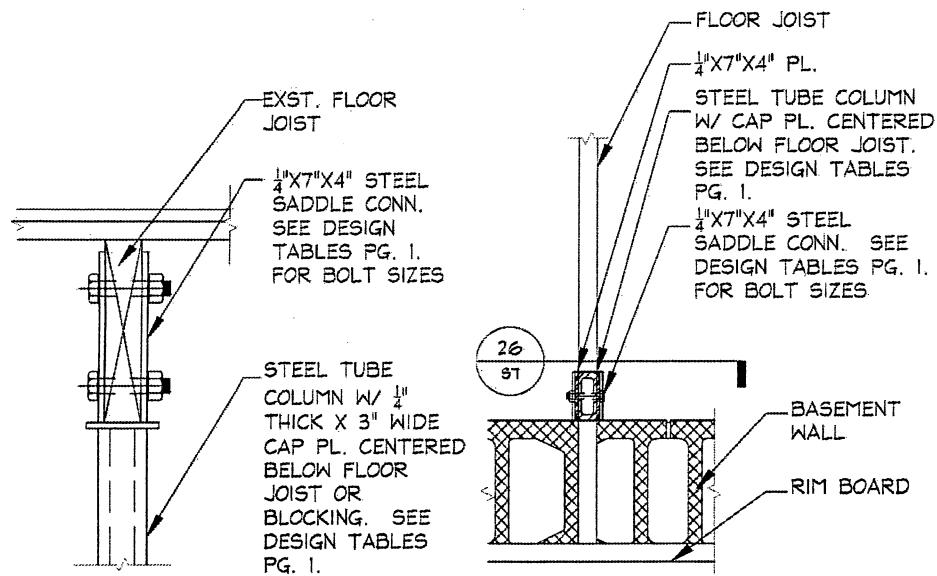

26 CONNECTION DETAIL SECTION  
1 1/2" = 1'-0"

27 TOP CONNECTION DETAIL  
3/4" = 1'-0"

28 TOP CONNECTION DETAIL  
3/4" = 1'-0"

TITLE: Top Connection W/Saddle

SHEET: S7, Appendix C

DRAWN: JFJ

DATE: 3/26/03

REVISION: 07/12/17

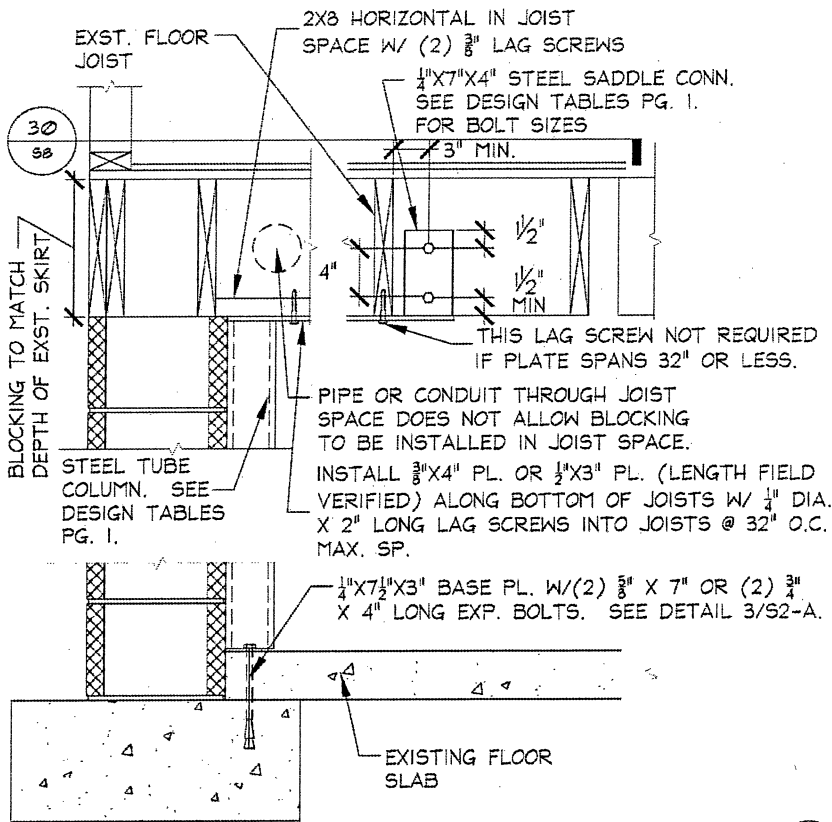

29 SADDLE OFFSET DETAIL 1 SIDE VIEW  
3/4" = 1'-0"

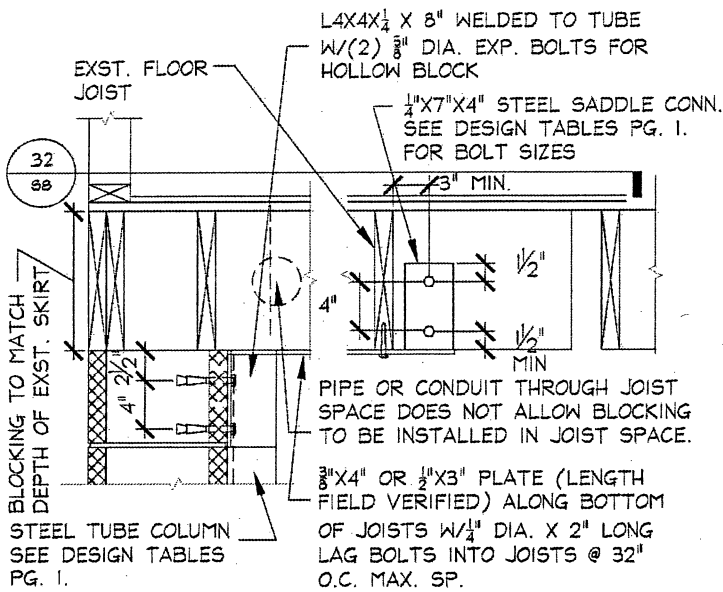

31 SADDLE OFFSET DETAIL 2 SIDE VIEW  
3/4" = 1'-0"

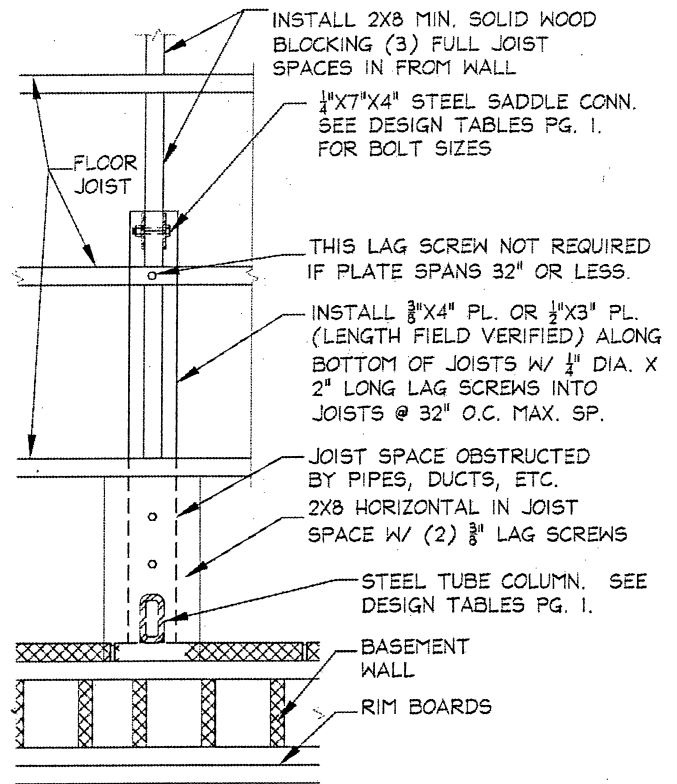

30 SADDLE OFFSET DETAIL 1 TOP VIEW  
3/4" = 1'-0"

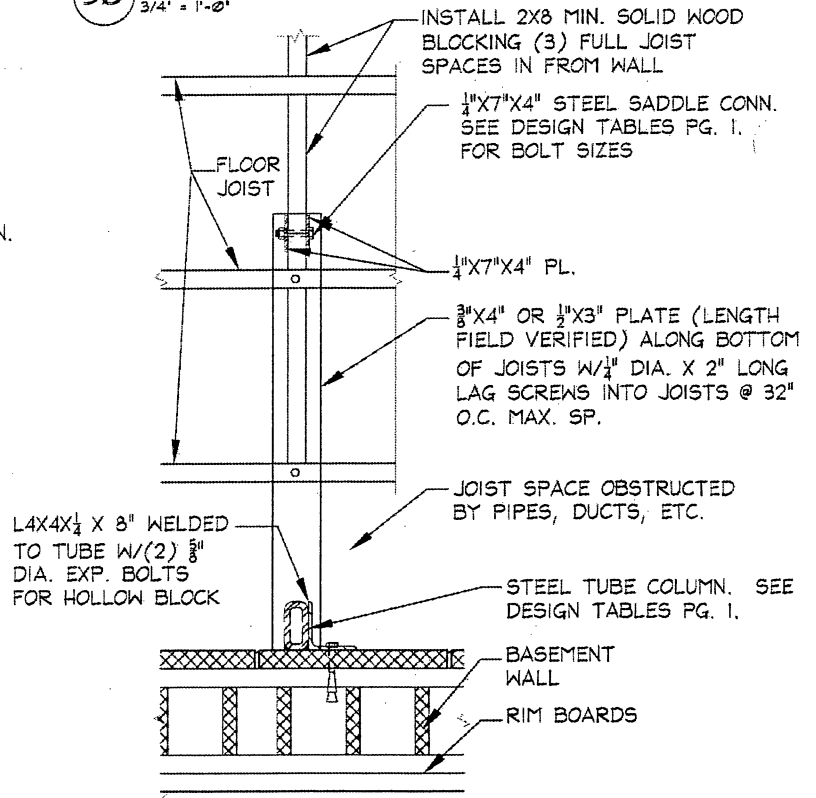

32 SADDLE OFFSET DETAIL 2 TOP VIEW  
3/4" = 1'-0"

TITLE: <b>Offset Top Connection Details</b>	
SHEET: S8, Appendix C	DRAWN: JFJ
DATE: 3/26/03	REVISION: 07/12/17

INSTALL 2X8 MIN. SOLID WOOD BLOCKING (3) FULL JOIST SPACES IN FROM WALL

STEEL TUBE SINGLE JOIST SIDE MOUNTED. SEE DESIGN TABLES PG. 1. FOR BOLT SIZES. MATCH SIZE OF VERTICAL TUBE COLUMN.

INSTALL 2X8 MIN. SOLID WOOD BLOCKING (3) FULL JOIST SPACES IN FROM WALL

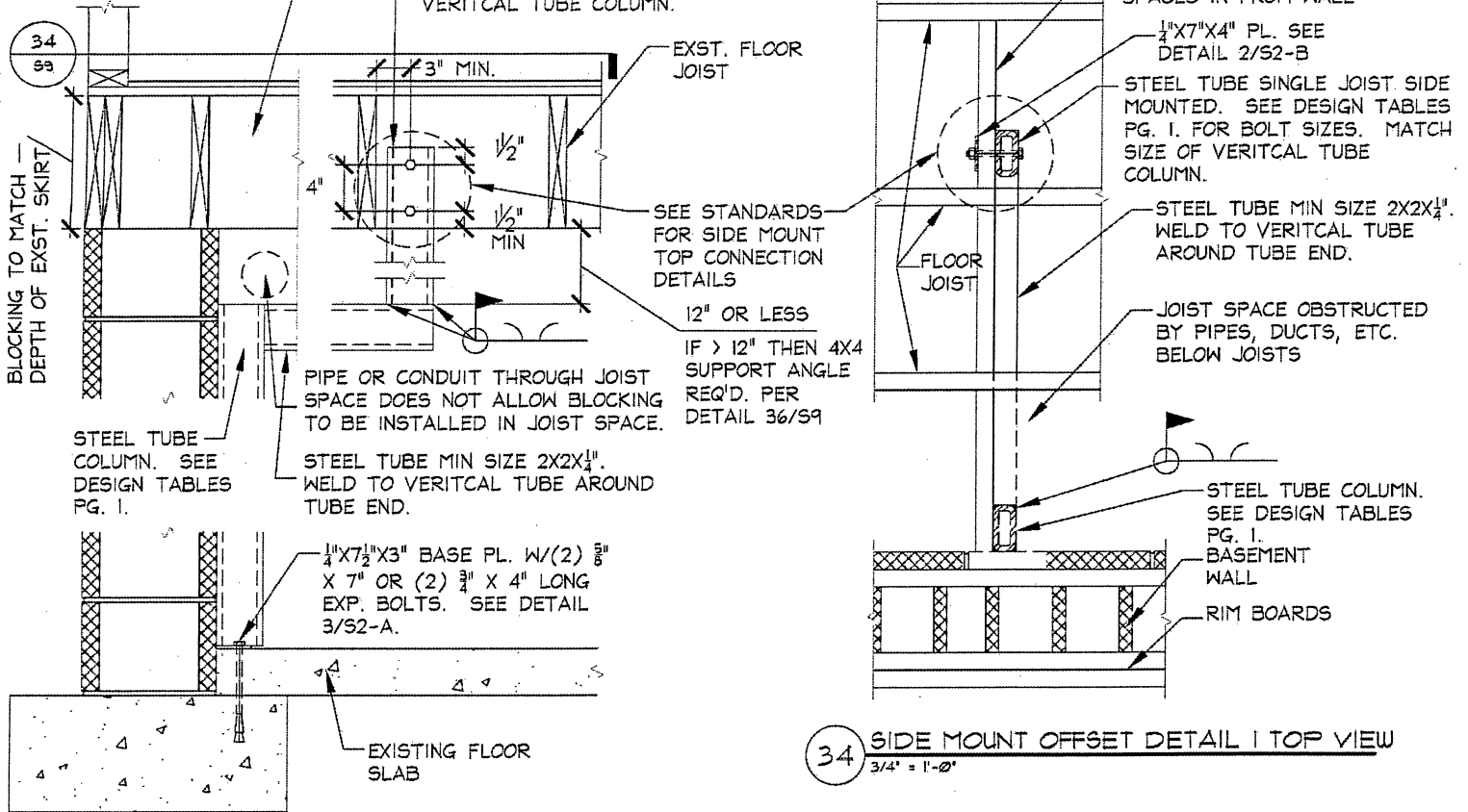

34 SIDE MOUNT OFFSET DETAIL I TOP VIEW  
3/4" = 1'-0"

33 SIDE MOUNT OFFSET DETAIL I SIDE VIEW  
3/4" = 1'-0"

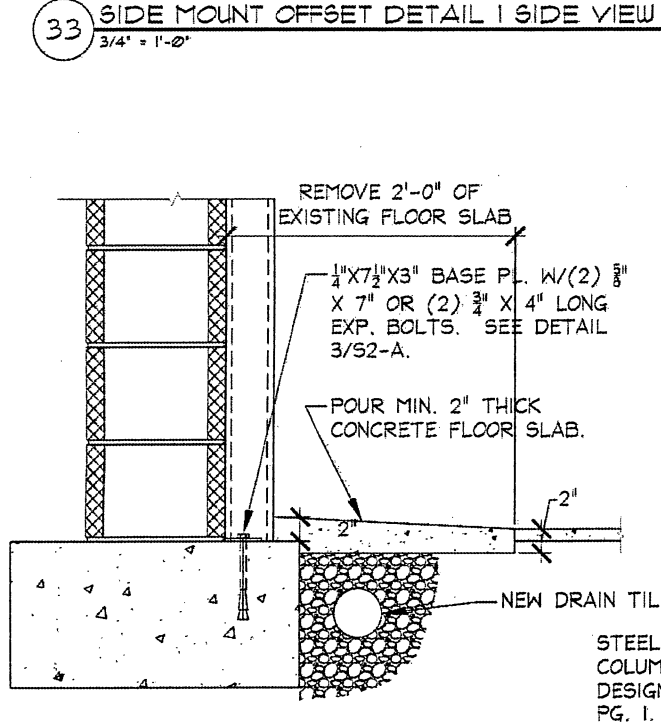

35 NEW DRAIN TILE @ THIN SLAB  
3/4" = 1'-0"

NOTE: INSTALL WALL DRAINAGE BD. AS REQ'D.

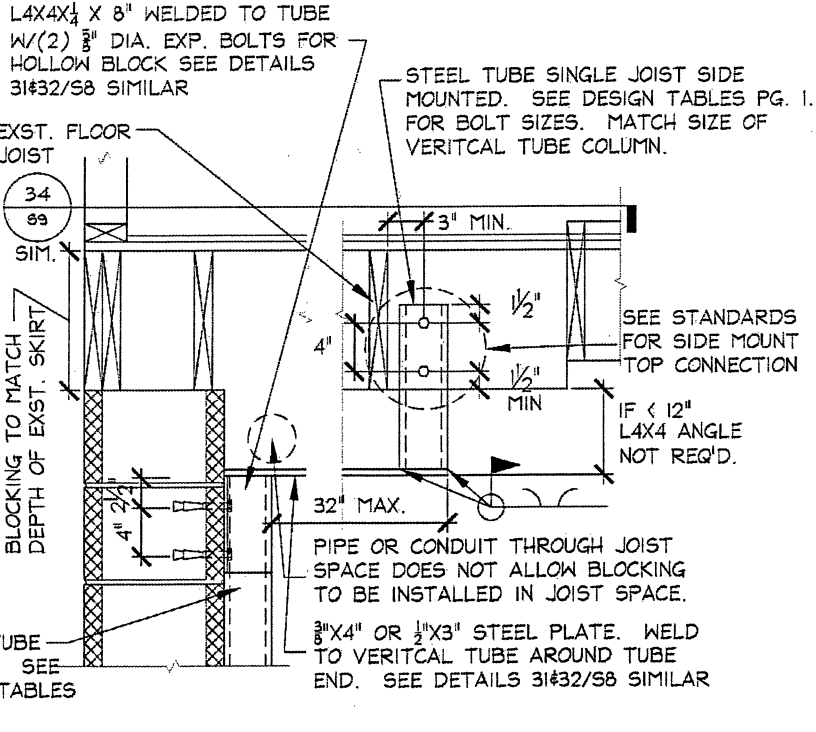

36 SIDE MOUNT OFFSET DETAIL 2 SIDE VIEW  
3/4" = 1'-0"

TITLE: <b>Offset &amp; Drain Tile Details</b>	
SHEET: S9, Appendix C	DRAWN: JFJ
DATE: 01/08/08	REVISION: 07/12/17

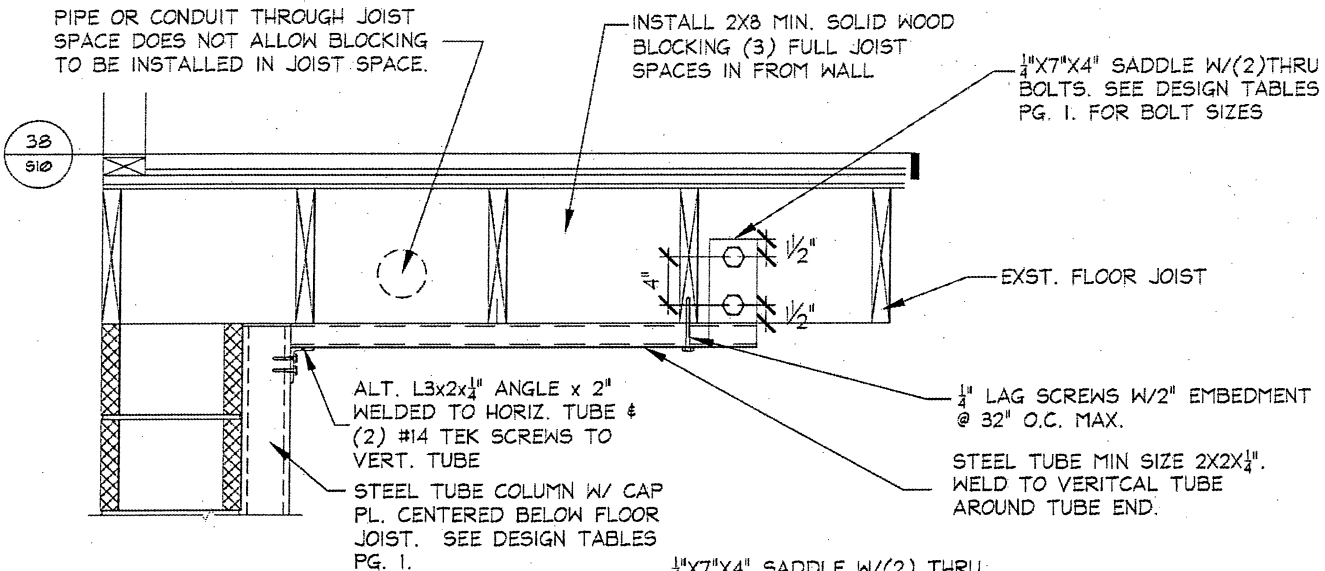

37 SADDLE OFFSET DETAIL 3 TOP VIEW  
3/4" = 1'-0"

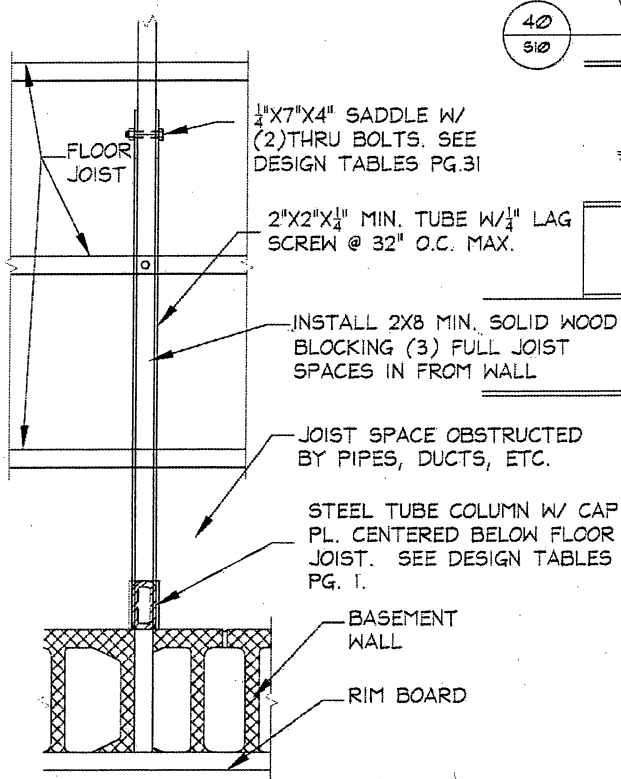

38 SADDLE OFFSET DETAIL 3 TOP VIEW  
3/4" = 1'-0"

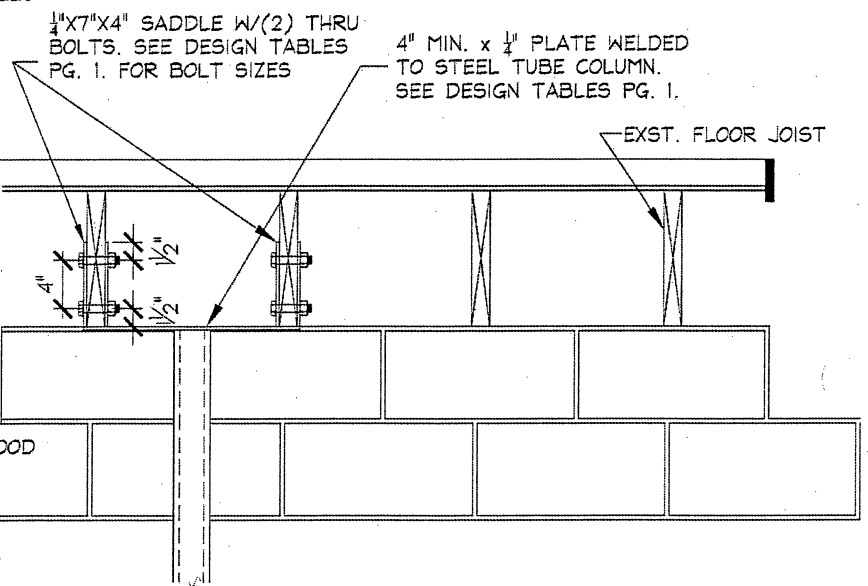

39 CONNECTION DETAIL SIDE VIEW  
3/4" = 1'-0"

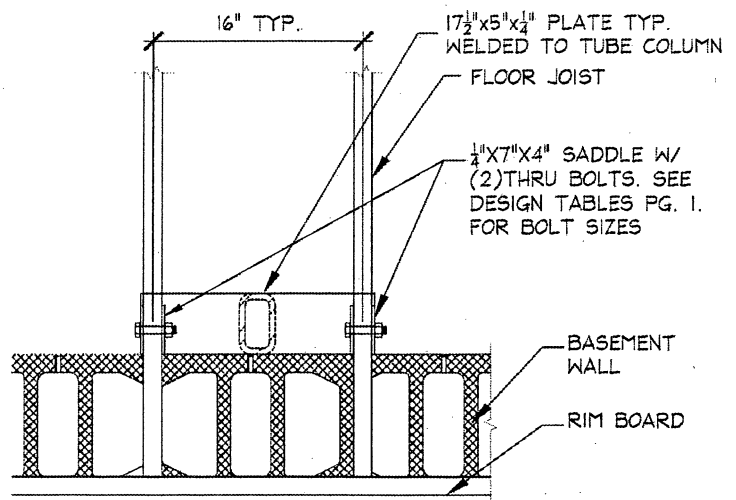

40 CONNECTION DETAIL TOP VIEW  
3/4" = 1'-0"

TITLE: Offset & Top Connection Details	
SHEET: S10, Appendix C	DRAWN: JFJ
DATE: 06/15/16	REVISION: 07/12/17



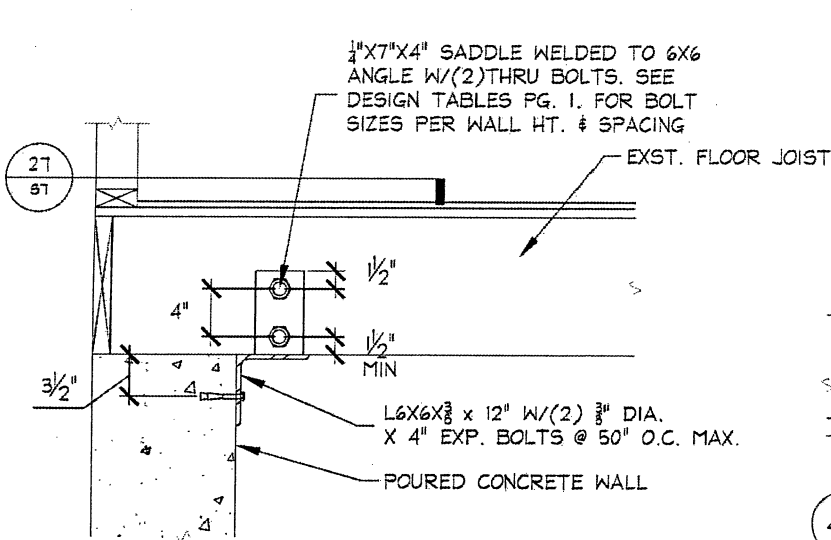

41 CONCRETE WALL DETAIL SIDE VIEW  
3/4" = 1'-0"

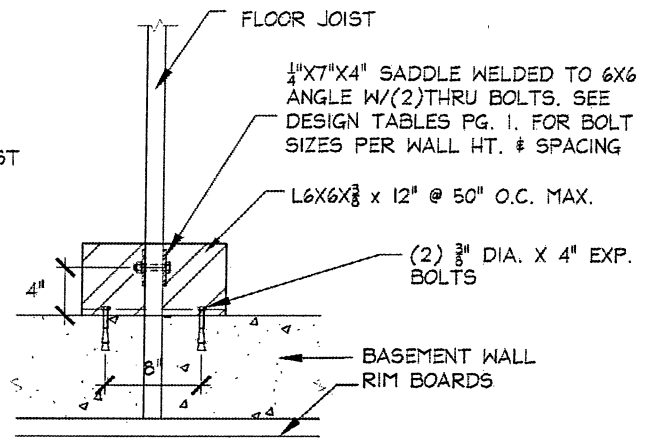

42 CONCRETE WALL DETAIL TOP VIEW  
3/4" = 1'-0"

NOTE: FOR NON-BRG. WALL, FOLLOW SADDLE CONNECTION DETAILS 25 & 28/S7 SIMILAR

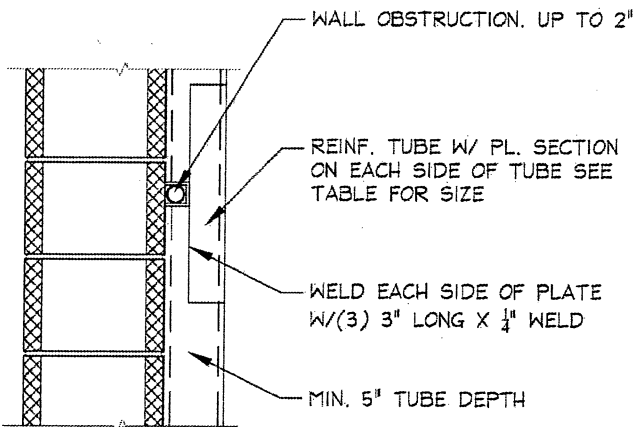

STEEL TUBE REINFORCING AROUND OBSTRUCTIONS			
WALL HT.	WALL REINF. #	SPACING	REINFORCING PLATES
10 COURSES (8'-10")	HSS 5"x2"x3/16"	3'-0"	(2) PL 1/4"x3"x18"
	HSS 5"x2"x3/16"	4'-2"	(2) PL 7/16"x3"x18"
11 COURSES (7'-8")	HSS 5"x2"x3/16"	3'-0"	(2) PL 3/8"x3"x18"
	HSS 6"x2"x3/16"	4'-2"	(2) PL 1/4"x4"x18"
12 COURSES (8'-2")	HSS 5"x3"x1/4"	3'-0"	(2) PL 1/2"x3"x18"
	HSS 6"x3"x1/4"	4'-2"	(2) PL 5/8"x4"x18"

\* 2X4 TUBES CAN BE USED IF NOTCH IS LESS THAN OR EQUAL TO 1"

43 TUBE REINFORCEMENT AROUND OBSTRUCTIONS  
3/4" = 1'-0"

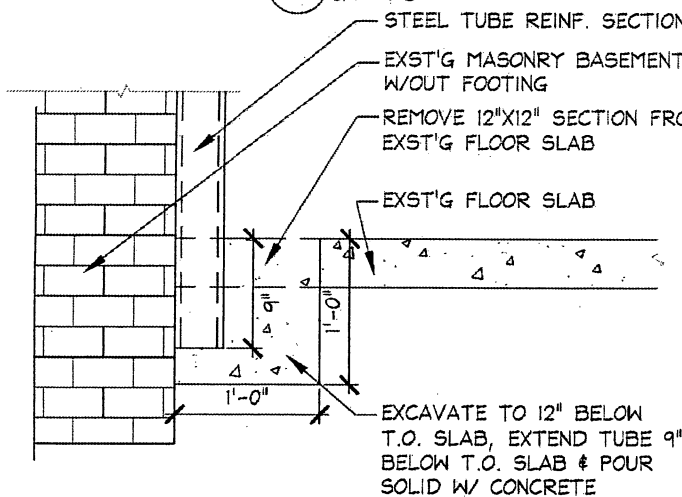

44 WALL REINFORCEMENT BOTTOM CONNECTION W/O FTG  
3/4" = 1'-0"

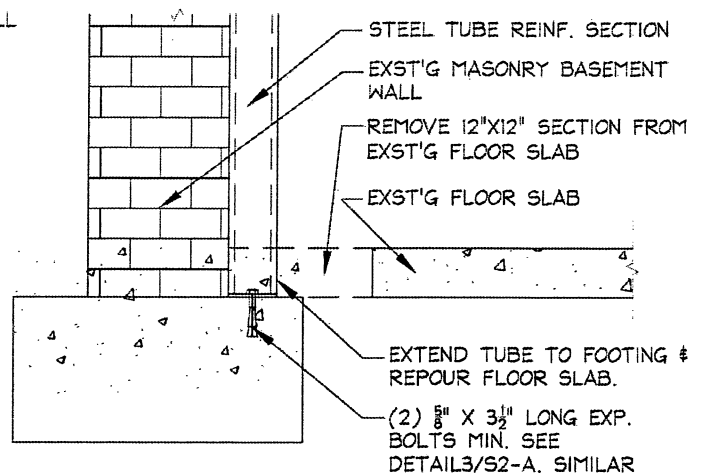

45 WALL REINFORCEMENT BOTTOM CONNECTION TO FTG  
3/4" = 1'-0"

TITLE: Concrete Wall & Misc. Repair Details	
SHEET: S11, Appendix C	DRAWN: JFJ
DATE: 3/26/03	REVISION: 07/12/17

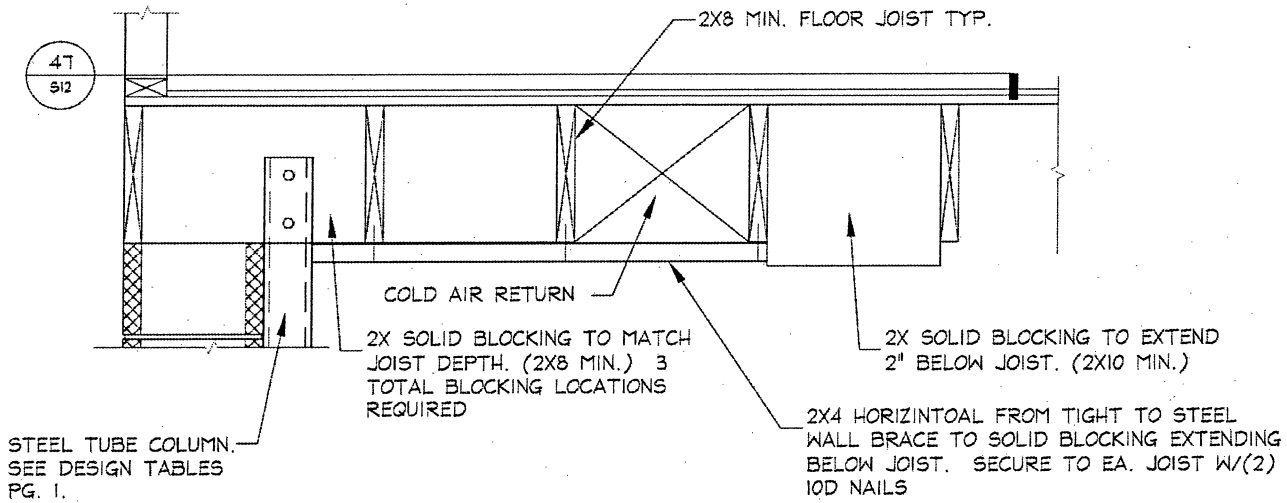

46 WOOD BLOCKING DETAIL SIDE VIEW  
3/4" = 1'-0"

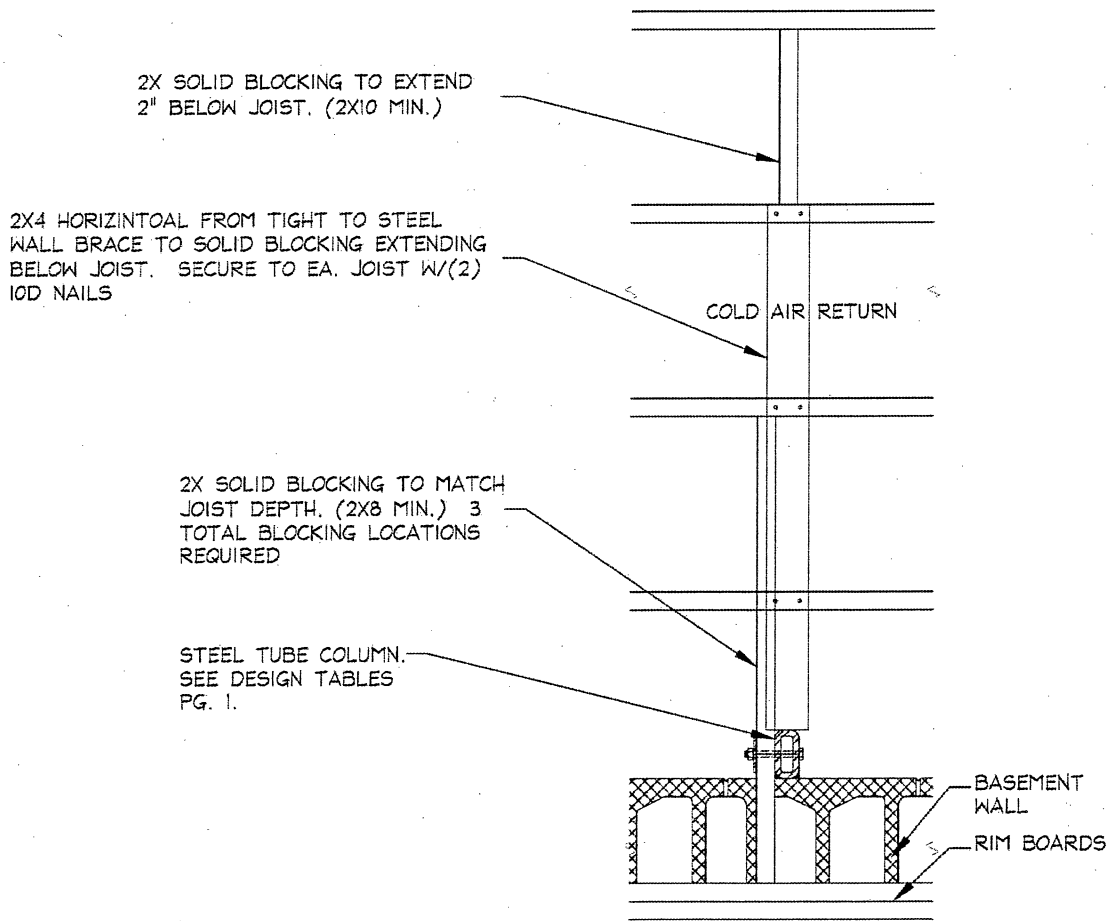

47 WOOD BLOCKING DETAIL TOP VIEW  
3/4" = 1'-0"

TITLE: Blocking Detail With Obstruction	
SHEET: S12, Appendix C	DRAWN: JFJ
DATE: 06/15/10	REVISION: 07/12/17