

CITY OF FRANKLIN
PLAN COMMISSION MEETING*
FRANKLIN CITY HALL COUNCIL CHAMBERS
9229 W. LOOMIS ROAD, FRANKLIN, WISCONSIN
AGENDA
THURSDAY, JANUARY 4, 2018, 7:00 P.M.

A. **Call to Order and Roll Call**

B. **Approval of Minutes**

1. Approval of regular meeting of December 21, 2017.

C. **Public Hearing Business Matters** (action may be taken on all matters following the respective Public Hearing thereon)

1. **OFF-STREET TRUCK LOADING REQUIREMENTS AND SPACE DESIGN UNIFIED DEVELOPMENT ORDINANCE TEXT AMENDMENT.** Unified Development Ordinance Text Amendment application by Kronos, Inc. to amend the Unified Development Ordinance text to amend §15-5.0205 OFF-STREET LOADING REQUIREMENTS, specifically §§15-5.0205B. and 15-5.0205F., and to amend §15-5.0206 OFF-STREET LOADING SPACE DESIGN, specifically §15-5.0206B., to provide some flexibility with regard to and to allow for the use of public streets for truck loading and unloading delivery services purposes, primarily in industrial areas involving a dead end street. **A PUBLIC HEARING IS SCHEDULED FOR THIS MEETING UPON THIS MATTER.**

D. **Business Matters** (no Public Hearing is required upon the following matters; action may be taken on all matters)

1. **MOLLY MAID PROFESSIONAL HOME CLEANING SERVICE BUSINESS USE.** Special Use application by R & R Swan Investments, LLC d/b/a Molly Maid, to operate a maid service business with hours of operation from 7:00 a.m. to 5:00 p.m., Monday through Friday, which application also includes a property owner requested revised Site Plan approval for existing site improvements constructed without prior City approval, specifically, reconfiguration of the parking lot in the northwest corner of the property and addition of a new parking lot in the rear of the property, upon property zoned M-1 Limited Industrial District and C-1 Conservancy District, located at 11113 West Forest Home Avenue, Suite 200; Tax Key No. 704-9978-002. [THE PUBLIC HEARING WAS HELD AT THE PLAN COMMISSION MEETING ON DECEMBER 7, 2017. SUBJECT MATTER CONTINUED FROM THE DECEMBER 7, 2017 MEETING.]

Franklin Plan Commission Agenda

1/4/18

Page 2

2. **FABU EYES EYELASH EXTENSION SERVICE BUSINESS USE.** Special Use application by Yulia Da Silva, owner, Fabu LLC, d/b/a Fabù Eyes, to operate an eyelash extension service business with hours of operation from 9:00 a.m. to 7:00 p.m., Monday through Friday, and 9:00 a.m. to 2:00 p.m., Saturday and Sunday, upon property zoned M-1 Limited Industrial District and C-1 Conservancy District, located at 11113 West Forest Home Avenue, Suite 240; Tax Key No. 704-9978-002. [THE PUBLIC HEARING WAS HELD AT THE PLAN COMMISSION MEETING ON DECEMBER 7, 2017. SUBJECT MATTER CONTINUED FROM THE DECEMBER 7, 2017 MEETING.]

E. Adjournment

*Supporting documentation and details of these agenda items are available at City hall during normal business hours.

**Notice is given that a majority of the Common Council may attend this meeting to gather information about an agenda item over which they have decision-making responsibility. This may constitute a meeting of the Common Council per *State ex rel. Badke v. Greendale Village Board*, even though the Common Council will not take formal action at this meeting.

[Note: Upon reasonable notice, efforts will be made to accommodate the needs of disabled individuals through appropriate aids and services. For additional information, contact the City Clerk's office at (414) 425-7500.]

REMINDERS:

Next Regular Plan Commission Meeting: January 18, 2018

**City of Franklin
Plan Commission Meeting
December 21, 2017
Minutes**

Unapproved

A. Call to Order and Roll Call

Mayor Steve Olson called the December 21, 2017 regular Plan Commission meeting to order at 7:00 p.m. in the Fadrow Room at the Franklin Public Library, 9151 West Loomis Road, Franklin, Wisconsin.

Present was Commissioners, Adam Burckhardt and Kevin Haley and City Engineer Glen Morrow. Excused was Commissioners David Fowler, Patricia Hogan and Alderman Dandrea. Also present was Planning Manager Joel Dietl and Principal Planner Nick Fuchs.

B. Approval of Minutes

1. Regular Meeting of December 7, 2017. Commissioner Haley moved and City Engineer Morrow seconded approval of the December 7, 2017 minutes of the regular meeting of the Plan Commission. On voice vote, all voted 'aye'. Motion carried (4-0-3).

C. Public Hearing Business Matters

2. **JEMCO ELECTRIC ELECTRICAL CONTRACTOR BUSINESS USE.** Special Use application by John Prusinski, owner and operator of Jemco, LLC d/b/a Jemco Electric, to operate an electrical contractor business within the former Woodcrest Market building located at 11610 West Rawson Avenue, which will include numerous building and site improvements over a 2 to 3 year period, with Jemco, LLC d/b/a Jemco Electric as the primary building tenant, and remodeling of the former attached residence into office space to lease to a future tenant, upon property zoned B-2 General Business District; Tax Key No. 749-9999-000.

Planning Manager Joel Dietl presented the request by John Prusinski, owner and operator of Jemco, LLC d/b/a Jemco Electric, to operate an electrical contractor business within the former Woodcrest Market building located at 11610 West Rawson Avenue, which will include numerous building and site improvements over a 2 to 3 year period, with Jemco, LLC d/b/a Jemco Electric as the primary building tenant, and remodeling of the former attached residence into office space to lease to a future tenant, upon property zoned B-2 General Business District.

The Official Notice of Public Hearing was read in to the record by Principal Planner Fuchs and the Public Hearing was opened at 7:03 and closed at 7:08.

Commissioner Haley moved and Commissioner Burckhardt seconded a motion to recommend approval of a resolution imposing conditions and restrictions for the approval of a Special Use for an electrical contractor business use upon property located at 11610 West Rawson Avenue. On voice vote, all voted 'aye'. Motion carried (4-0-3).

D. Business Matters**1. WHITNALL YOUTH BASEBALL, INC. SPORTS GROUP INDOOR PHYSICAL FITNESS/PRACTICE FACILITY.**

Temporary Use application by Michael Phillip Meyer, President of Whitnall Youth Baseball, Inc., for operation of a public youth baseball and softball indoor physical fitness/practice facility use for boys and girls ranging in age from 4 to 16, from communities all around southeastern Wisconsin, at approximately 6542 South Lovers Lane Road, in the Garden Plaza Shopping Center, between January 8, 2018 and April 8, 2018, from 5:00 p.m. to 9:00 p.m. Monday through Friday and from 9:00 a.m. to 6:00 p.m. on Saturdays and Sundays, on property zoned B-3 Community Business District; Tax Key No. 705-8997-004.

Planning Manager Joel Dietl presented the request by Michael Phillip Meyer, President of Whitnall Youth Baseball, Inc., for operation of a public youth baseball and softball indoor physical fitness/practice facility use for boys and girls ranging in age from 4 to 16, from communities all around southeastern Wisconsin, at approximately 6542 South Lovers Lane Road, in the Garden Plaza Shopping Center, between January 8, 2018 and April 8, 2018, from 5:00 p.m. to 9:00 p.m. Monday through Friday and from 9:00 a.m. to 6:00 p.m. on Saturdays and Sundays, on property zoned B-3 Community Business District.

Commissioner Haley moved and Commissioner Burckhardt seconded a motion to approve a resolution imposing conditions and restrictions for the approval of a Temporary Use for an indoor physical fitness/practice facility use for property located at 6542 South Lovers Lane Road (Garden Plaza Shopping center). On voice vote, all voted 'aye'. Motion carried (4-0-3).

C. Public Hearing Business Matters

1. PLANNED DEVELOPMENT DISTRICT NO. 37 (THE ROCK SPORTS COMPLEX/BALLPARK COMMONS) ORDINANCE TERMS AND USES AMENDMENTS, STADIUM SPECIAL USE AND NATURAL RESOURCES SPECIAL EXCEPTIONS. Planned Development District Amendment, Special Use and Natural Resource Features Special Exception applications by Ballpark Commons, LLC, applicant, Zim-Mar Properties, LLC, Milwaukee County, Wisconsin Department of Transportation and FF & E, LLC property owners, as follows:

Planned Development District Amendment to revise the district in the following manner: to allow additional uses as permitted uses, including but not limited to sports medicine medical offices/facilities, indoor/outdoor golf

Natural Resource Features Special Exception

Planning Manager Joel Dietl presented the request by Ballpark Commons, LLC, applicant, for a special exception to certain natural resource provisions of the City of Franklin Unified Development Ordinance for the purpose of allowing impact to various wetlands, wetland buffers, wetland setbacks, mature woodlands, floodplain, and shore buffer (approximately 38.92 total acres of protected natural resource features currently exist within the subject property) in order to construct the proposed Ballpark Commons sports anchored mixed use development. And to create new wetland; restore/enhance existing wetland; create new wetland buffers associated with two proposed stormwater management ponds; and create woodlands associated with a proposed berm along the entire western boundary of the Ballpark Commons project.

The Official Notice of Public Hearing was read in to the record by Principal Planner Fuchs and the Public Hearing was opened at 7:17 p.m. and closed at 8:37 p.m.

Commissioner Haley moved and City Engineer Morrow seconded a motion to recommend approval of the Ballpark

driving range, and indoor/outdoor entertainment uses, music and sporting events; to allow as a special use small engine go cart racing; to revise certain district standards including but not limited to building height and building setback limits; to include additional more detailed site information pertaining to public and private infrastructure such as streets, parking lots and stormwater management facilities; to include additional more detailed site information pertaining to the proposed multi-family residential apartments to be located south of West Rawson Avenue, and to the stadium, indoor sports facility and the retail/office/commercial buildings to be located north of West Rawson Avenue and to allow a three month extension of the first building permit time limit in condition number 27 in Planned Development District No. 37, Ordinance No. 2016-2212;

Special Use

to allow for construction and operation of a proposed stadium with seating for approximately 4,000 people that will serve as the home field for: an independent minor league baseball team; the University of Wisconsin-Milwaukee baseball team; and a professional and/or summer college soccer team; the stadium is proposed to be used as an extension of the current sports programming offered at The Rock Sports Complex including baseball tournaments, league play, and practices and the stadium is envisioned to host civic and/or entertainment events including farmer's markets, expos, ice skating, concerts, weddings, corporate events, fireworks, and other special events; the perimeter of the proposed Stadium will include such accessory uses and activities as entertainment, music, and fan engagement zones consisting of games, amusement rides,

Commons, LLC Natural Resource Features Special Exception pursuant to the Standards, Findings and Decision recommended by the Plan Commission and Common Council consideration of the Environmental Commission recommendations and Staff recommendations. On voice vote, all voted 'aye'. Motion carried (4-0-3).

Special Use

Planning Manager Joel Dietl presented the request by Ballpark Commons, LLC, applicant, for a Special Use to allow for construction and operation of a proposed stadium with seating for approximately 4,000 people that will serve as the home field for: an independent minor league baseball team; the University of Wisconsin-Milwaukee baseball team; and a professional and/or summer college soccer team. The stadium is proposed to be used as an extension of the current sports programming offered at The Rock Sports Complex; the stadium is envisioned to host civic and/or entertainment events; the perimeter of the proposed Stadium will include such accessory uses and activities as entertainment, music, and fan engagement zones; and the proposed stadium will serve food and beverages in a variety of ways (such proposed stadium use is to be located south of the ski hill).

The Official Notice of Public Hearing was read in to the record by Principal Planner Fuchs and the Public Hearing was opened at 8:53 p.m. and closed at 9:17 p.m.

City Engineer Morrow moved and Commissioner Haley seconded a motion to recommend approval of a Resolution imposing conditions and restrictions for the approval of a Special Use for construction and operation of a proposed outdoor baseball/soccer stadium use upon property located at 7900 West Crystal Ridge Drive. On voice vote, all voted 'aye'. Motion carried (4-0-3).

Planned Development District Amendment

Planning Manager Joel Dietl presented the request by Ballpark Commons, LLC, applicant, to revise the district in the following manner: to allow additional uses as permitted uses; to allow additional uses as special uses, to revise certain district standards; to include additional more detailed site information; and to allow a three month extension of the first building permit time limit in condition number 27 in Planned Development District No. 37, Ordinance No. 2016-2212.

and various activities for children and adults; the proposed stadium will serve food and beverages in a variety of ways utilizing traditional concession stands, open air and mobile concessions, and food trucks (such proposed stadium use is to be located south of the ski hill);

Natural Resource Features Special Exception for the purpose of allowing impact to various wetlands, wetland buffers, wetland setbacks, mature woodlands, floodplain, and shore buffer (approximately 38.92 total acres of protected natural resource features currently exist within the subject property) in order to construct the proposed Ballpark Commons sports anchored mixed use development. In summary, the applicant is requesting to: clear, grade, fill and develop approximately 23.08 acres of protected natural resource features comprised of the following: approximately 2.0 acres of wetlands which have received an Artificial/Exempt Wetland Determination from the Wisconsin Department of Natural Resources; approximately 1.35 acres of non-exempt wetlands; approximately 4.27 acres of wetland buffers; approximately 4.31 acres of wetland setbacks; approximately 10.97 acres of mature woodlands; approximately 0.18 acre of floodplain; create approximately 0.75 acre of new wetland; restore/enhance approximately 0.55 acre of existing wetland; create approximately 5.5 acres of new wetland buffers associated with two proposed stormwater management ponds and create approximately 8.5 acres of woodlands associated with a proposed berm along the entire western boundary of the Ballpark Commons project [it is noted that of the proposed impacts, approximately 2.0 acres consist of wetlands which have been exempted from regulation/protection by the

The Official Notice of Public Hearing was read in to the record by Principal Planner Fuchs and the Public Hearing was opened at 9:29 p.m. and closed at 10:05 p.m.

City Engineer Morrow moved and Commissioner Haley seconded a motion to recommend approval of an Ordinance to amend Section 15-3.0442 of the Unified Development Ordinance Planned Development District No. 37 (The Rock Sports Complex/Ballpark Commons) to revise the district in the following manner: To allow additional uses as permitted uses, including but not limited to indoor/outdoor golf driving range, and indoor/outdoor entertainment uses, music and sporting events; to all as a Special Use small engine electric go cart racing; to revise certain district standards including but not limited to building height and building setback limits: to include additional more detailed site information pertaining to public and private infrastructure such as streets, parking lots and stormwater management facilities; to include additional more detailed site information pertaining to the proposed Multi-Family Residential apartments to be located south of West Rawson Avenue, and to the stadium, indoor sports facility and the retail/office/commercial buildings to be located north of West Rawson Avenue and to allow a three month extension of the first building permit time limit in condition number 27 in Planned Development District No. 37, Ordinance No. 2016-2212 (7900 West Crystal Ridge Drive), in reference to tracked change draft Ordinance. On voice vote, all voted 'aye'. Motion carried (4-0-3).

Wisconsin Department of Natural Resources, and that approximately 0.18 acre consist of floodplain which is being impacted by a stormwater pond's rip-rap outfall and by a sanitary sewer extension which are permitted activities within the floodplain]; all property located at 7900 West Crystal Ridge Drive, zoned Planned Development District No. 37 (The Rock Sports Complex/Ballpark Commons) and FW Floodway District. Tax Key Nos. 745-8998-000, 744-8985-001, 744-8985-002, 744-8989-000, 744-8988-000, 755-9996-000, 754-9988-002, 755-9995-001, 708-8996-000, 708-8999-000, 744-8980-001, 745-0029-000, 745-8999-004, 755-9995-002, 754-9988-001, 744-8981-000 [all preceding Tax Key Nos. are Planned Development District No. 37 (The Rock Sports Complex/Ballpark Commons) zoning, with the exception of Tax Key Nos. 708-8996-000 and 744-8980-001 which are zoned Planned Development District No. 37 (The Rock Sports Complex/Ballpark Commons) and FW Floodway District] [the properties which are the subject of the Special Use application bear Tax Key Nos. (all or portions of parcels) 744-8980-001, 744-8989-000, 744-8988-000 and 744-8985-001 ((The Rock Sports Complex/Ballpark Commons) and FW Floodway District (Tax Key No. 744-8980-001 only)].

E. Adjournment

Commissioner Haley moved and Commissioner Burckhardt seconded to adjourn the Plan Commission meeting of December 21, 2017 at 10:08 p.m. All voted 'aye'; motion carried. (4-0-3).



CITY OF FRANKLIN
REPORT TO THE PLAN COMMISSION

Meeting of January 4, 2018

Unified Development Ordinance Text Amendment

RECOMMENDATION: Department of City Development staff recommends approval of the proposed Unified Development Ordinance Text Amendment in regard to Off-Street Loading requirements (i.e. truck maneuvering within public rights-of-way) subject to the conditions and restrictions within the draft ordinance.

Project Name:	Krones, Inc. Unified Development Ordinance Text Amendment
Project Location:	City-wide
Applicant:	Krones, Inc.
Agent:	Thomas Schulz, Krones, Inc.
Applicant's Action Requested:	Approval of the Unified Development Ordinance to allow truck maneuvering in industrial districts within City rights-of-way

Please note:

- Staff suggestions are *in italics* and are not included in the draft ordinance.

INTRODUCTION:

On December 5, 2017, the applicant filed a Unified Development Ordinance Text Amendment Application initially requesting the following changes to the UDO:

- Section 15-5.0205B. to insert “generally” between “areas” and “other.” See excerpt below.
 Loading spaces on lots located adjacent to public ways shall be so situated as to enable the vehicles to back into the loading dock from areas *generally* other than public ways.
- Section 15-5.0205F. to insert “generally” between “not” and “within” and add at the end of the section, “In industrial districts, a dead-end right of way may serve as off-street truck maneuvering when adequate information is provided describing how it meets the intent of this section.” See excerpt below.
 Adequate off-street truck maneuvering area shall be provided on-site and not *generally* within any public street right-of-way or other public lands. *In industrial districts, a dead-end right of way may serve as off-street truck maneuvering when adequate information is provided describing how it meets the intent of this section.*

- Section 15-5.0206B. to insert “generally” between “areas” and “other.” See excerpt below.

Loading spaces on lots located on public ways shall be so situated as to enable the vehicles to back into the loading dock from areas *generally* other than the public way.

HISTORY:

Recently, the Plan Commission approved a Site Plan for construction of a 40,000 square foot pre-engineered metal building on property located across the street from Kronos, Inc.’s North American headquarters at 9611 South 58th Street.

The Site Plan approval included the condition below.

“The site plan shall be redesigned to accommodate all truck movements onsite, subject to review and approval by the Department of City Development. Alternatively, a Unified Development Ordinance Text Amendment Application shall be approved to allow truck maneuverability within public rights-of-way prior to issuance of a Building Permit.”

As such, the applicant is requesting the Unified Development Ordinance Text Amendment.

Note that the City also approved a Natural Resource Special Exception related to the proposed project to allow the applicant to permanently fill and remove approximately 6,750 square feet of wetland buffer and 13,670 square feet of wetland setback to allow for construction of the proposed building and parking lot.

PROJECT DESCRIPTION/ANALYSIS:

The proposed UDO Text Amendment would affect all properties zoned M-1, M-2 and BP Districts. Specifically for Kronos, Inc., the request is being made as the approved site plan includes a loading dock on the north side of the proposed building that requires trucks to maneuver within City right-of-way (S. 58th Street), as opposed to accommodating all truck movements onsite as is currently required by the Unified Development Ordinance.

Following staff review of the applicant’s proposed UDO changes; staff recommended the proposed amendment language be revised as indicated below. The applicant agreed with these revisions and submitted a revised request accordingly.

SECTION 15-5.0205 OFF-STREET LOADING REQUIREMENTS

Off-street loading spaces accessory to designated uses shall be provided as follows:

- B. **Access.** Each required off-street loading space shall be designed with appropriate means of vehicular access to a street or alley in a manner which will least interfere with traffic movement. Loading spaces on lots located adjacent to public ways shall be so situated as to enable the vehicles to back into the loading dock from areas other than public ways, *unless as otherwise approved by the Plan Commission per subsection 15-5.0205F*. The blocking of loading spaces by other loading spaces, permanent or moveable

structures of any type, including trash receptacles or compactors, shall be prohibited.

- F. **Maneuvering Space Required to Service Outdoor Loading Areas.** Adequate off-street truck maneuvering area shall be provided on-site and not within any public street right-of-way or other public lands, *except as may be allowed by the Plan Commission for properties located within the M-1, M-2 and BP Districts where permanently dead-ended streets and cul-de-sacs may serve as off-street truck maneuvering when the Plan Commission has considered the number of proposed loading docks, the proposed use and frequency of loading and unloading, and the number of businesses located on the dead-end street or cul-de-sac; and has determined that the adjacent businesses will not be adversely impacted or affected.*

Staff would suggest that the proposed change to Section 15-5.0205F. also include Plan Commission consideration of potential adverse impacts to the City right-of-way and street pavement and Plan Commission authority to require if deemed necessary a Letter of Credit or other approved financial security sufficient to ensure repair of any damage to the public right-of-way or public street.

SECTION 15-5.0206 OFF-STREET LOADING SPACE DESIGN

- B. **Minimum Required Off-Street Loading Spaces Accessory to Nonresidential Uses in Industrial Districts.** The minimum number and size of off-street loading spaces accessory to uses in the M-1, M-2, and BP Districts shall be in accordance with Table 15-5.0206. For each additional one hundred thousand (100,000) square feet of gross floor area, or fraction thereof, over one hundred thousand (100,000) square feet of gross floor area, one (1) additional loading space shall be provided. Such additional space shall be a minimum of twelve (12) feet in width by fifty (50) feet in length, and have a vertical clearance of not less than fifteen (15) feet. ~~*Loading spaces on lots located on public ways shall be so situated as to enable the vehicles to back into the loading dock from areas other than the public way.*~~

STAFF RECOMMENDATION:

Even with the staff recommended language, Department of City Development and Engineering Department staff has concerns and reservations related to the proposed Unified Development Ordinance Text Amendment, which would allow trucks to utilize rights-of-way for loading and unloading traffic movements. Staff concerns relate to long-term impacts such as increased wear and tear on City roads, as well as the potential adverse impacts on traffic and adjacent loading and unloading.

With that said, Staff finds the amendment is limited enough in scope to recommend approval of the Unified Development Ordinance Text Amendment subject to the conditions and restrictions within the draft ordinance.

ORDINANCE NO. 2018-_____

AN ORDINANCE TO AMEND THE UNIFIED DEVELOPMENT
ORDINANCE TEXT TO AMEND §15-5.0205 OFF-STREET LOADING
REQUIREMENTS, SPECIFICALLY §§15-5.0205B. AND 15-5.0205F., AND TO
AMEND §15-5.0206 OFF-STREET LOADING SPACE DESIGN, SPECIFICALLY §15-
5.0206B., TO PROVIDE SOME FLEXIBILITY WITH REGARD TO AND TO ALLOW
FOR THE USE OF PUBLIC STREETS FOR TRUCK LOADING AND UNLOADING
DELIVERY SERVICES PURPOSES, PRIMARILY IN INDUSTRIAL AREAS
INVOLVING A DEAD END STREET
(KRONES, INC., APPLICANT)

WHEREAS, §15-5.0205B. Access of the Unified Development Ordinance requires in part that each required off-street loading space shall be designed with appropriate means of vehicular access to a street or alley in a manner which will least interfere with traffic movement and loading spaces on lots located adjacent to public ways shall be so situated as to enable the vehicles to back into the loading dock from areas other than public ways, §15-5.0205F. Maneuvering Space Required to Service Outdoor Loading Areas of the Unified Development Ordinance requires that adequate off-street truck maneuvering area shall be provided on-site and not within any public street right-of-way or other public lands and §15-5.0206B. Minimum Required Off-Street Loading Spaces Accessory to Nonresidential Uses in Industrial Districts of the Unified Development Ordinance requires in part that loading spaces on lots located on public ways shall be so situated as to enable the vehicles to back into the loading dock from areas other than the public way; and

WHEREAS, Kronos, Inc. having applied for a text amendment to §§§15-5.0205B., 15-5.0205F. and 15-5.0206B. of the Unified Development Ordinance so as to provide some flexibility with regard to and to allow for the use of public streets for truck loading and unloading delivery services purposes, primarily in industrial areas involving a dead end street; and

WHEREAS, the Plan Commission having reviewed the proposed amendments to provide some flexibility with regard to and to allow for the use of public streets for truck loading and unloading delivery services purposes, primarily in industrial areas involving a dead end street, and having held a public hearing on the proposal on the 4th day of January, 2018 and thereafter having recommended approval of such amendments; and

WHEREAS, the Common Council having accepted the recommendation of the Plan Commission and having determined that the proposed amendments are consistent with the 2025 Comprehensive Master Plan of the City of Franklin, Wisconsin and will serve to further orderly growth and development and promote the health, safety and welfare of the Community.

NOW, THEREFORE, the Mayor and Common Council of the City of Franklin, Wisconsin, do ordain as follows:

- SECTION 1: §15-5.0205 OFF-STREET LOADING REQUIREMENTS, specifically §15-5.0205B. Access of the Unified Development Ordinance of the Municipal Code of the City of Franklin, Wisconsin is hereby amended as follows: insert “unless as otherwise approved by the Plan Commission per subsection 15-5.0205F.” following “ways” at the end of the second last sentence in the paragraph.
- SECTION 2: §15-5.0205 OFF-STREET LOADING REQUIREMENTS, specifically §15-5.0205F. Maneuvering Space Required to Service Outdoor Loading Areas of the Unified Development Ordinance of the Municipal Code of the City of Franklin, Wisconsin is hereby amended as follows: insert “except as may be allowed by the Plan Commission for properties located within the M-1, M-2 and BP Districts where permanently dead-ended streets and cul-de-sacs may serve as off-street truck maneuvering when the Plan Commission has considered the number of proposed loading docks, the proposed use and frequency of loading and unloading and the number of businesses located on the dead-end street or cul-de-sac and has determined that the adjacent businesses will not be adversely impacted or affected” following “lands” at the end of the first sentence in the paragraph.
- SECTION 3: §15-5.0206 OFF-STREET LOADING SPACE DESIGN, specifically §15-5.0206B. Minimum Required Off-Street Loading Spaces Accessory to Nonresidential Uses in Industrial Districts of the Unified Development Ordinance of the Municipal Code of the City of Franklin, Wisconsin is hereby amended as follows: delete “Loading spaces on lots located on public ways shall be so situated as to enable the vehicles to back into the loading dock from areas other than the public way.”, the last sentence in the paragraph.
- SECTION 4: The terms and provisions of this ordinance are severable. Should any term or provision of this ordinance be found to be invalid by a court of competent jurisdiction, the remaining terms and provisions shall remain in full force and effect.
- SECTION 5: All ordinances and parts of ordinances in contravention to this ordinance are hereby repealed.

SECTION 6: This ordinance shall take effect and be in force from and after its passage and publication.

Introduced at a regular meeting of the Common Council of the City of Franklin this _____ day of _____, 2018, by Alderman _____.

Passed and adopted at a regular meeting of the Common Council of the City of Franklin this _____ day of _____, 2018.

APPROVED:

Stephen R. Olson, Mayor

ATTEST:

Sandra L. Wesolowski, City Clerk

AYES _____ NOES _____ ABSENT _____

9611 S. 58th Street
TKN 899 9990 062

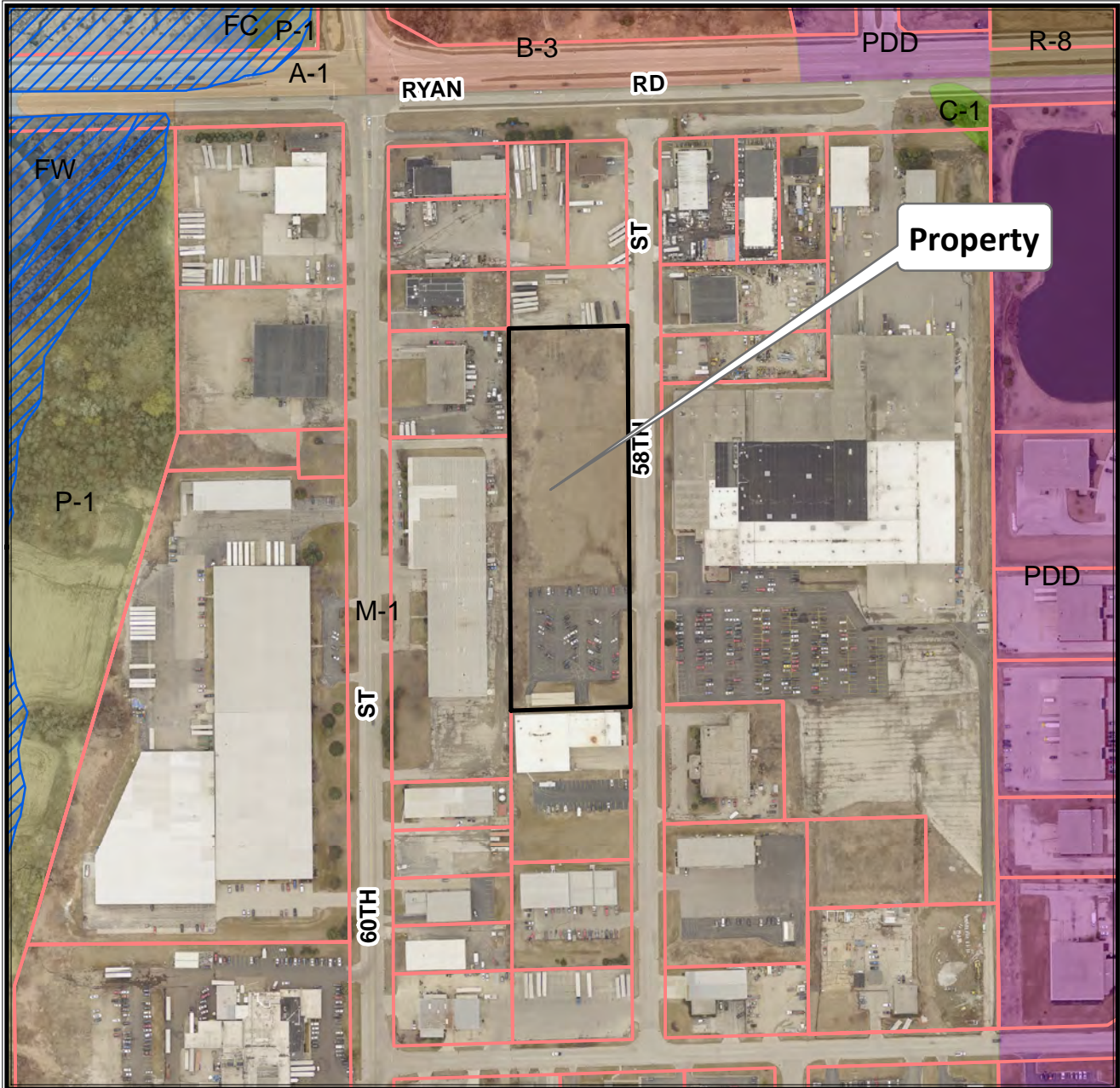

Planning Department
(414) 425-4024

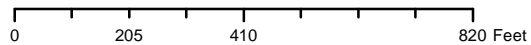

This map shows the approximate relative location of property boundaries but was not prepared by a professional land surveyor. This map is provided for informational purposes only and may not be sufficient or appropriate for legal, engineering, or surveying purposes.

9611 S. 58th Street
TKN 899 9990 062

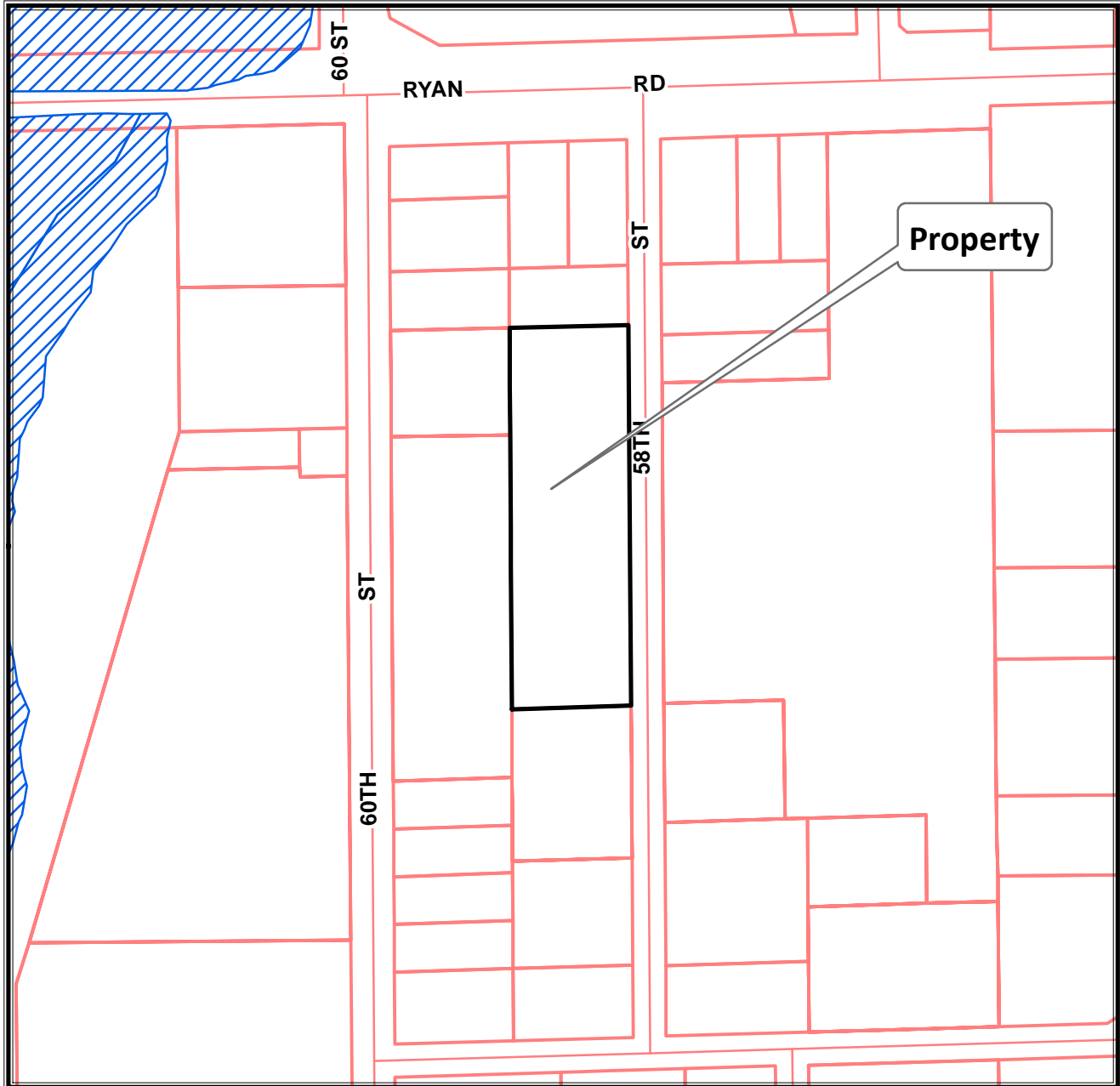

Planning Department
(414) 425-4024

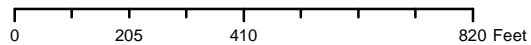

This map shows the approximate relative location of property boundaries but was not prepared by a professional land surveyor. This map is provided for informational purposes only and may not be sufficient or appropriate for legal, engineering, or surveying purposes.





City of Franklin
Planning Department

9229 West Loomis Road
Franklin WI, 53132

KRONES, INC.
9600 South 58th Street
P.O. Box 321801
Franklin, WI 53132-6241 USA

Thomas Schulz
Tel: (414) 409-4210
Cell: (414) 526-7166
T.schulz@kronesusa.com

Tuesday December 19, 2017

**Subject: Amendment to Unified Development Ordinance (UDO) Text Amendment
Submittal for Truck Maneuvering -SECTION 15-5.0205 OFF-STREET LOADING
REQUIREMENTS. (Reference letter dated December 1st for additional detail)**

Attention Planning Department:

**Based on feedback from city staff we are amending our proposed language suggestion for the
proposed UDO Text Amendment for Truck Maneuvering:**

- It is our request that the existing ordinance “SECTION 15-5.0205 OFF-STREET LOADING REQUIREMENTS” be amended to allow off-site maneuvering of trucks like that of adjacent properties that have been grandfathered prior to the generation of the current ordinance.
- The logistics strategy for the proposed building has very limited truck traffic, approximately two-three trucks per week.
- larger equipment in our showroom area will rotate every three years.
- The building is located near the end of a dead-end street with very limited traffic
- Krones is trying to optimize the available undeveloped land and reserve area for future expansion of this new building.

Project Narrative:

The proposed project consists of the construction of a 42,454-square foot pre-engineered metal building on a parcel of land adjacent to an existing parking lot. The property is currently owned by Krones and is located within the original Franklin industrial park. The East elevation of the building will be finished in flat architectural metal panel combined with several large storefront windows. The large storefront windows along the East are intended to showcase Krone’s current equipment offerings. The South elevation will be faced with flat architectural metal panel and punctuated with insulated aluminum windows intended to bring natural lighting deep into the interior of the building. The West elevation will be faced with ribbed metal panel. The North elevation will be a combination of ribbed metal panel and flat architectural metal panels. The roof of the building will be a standing seam metal panel system with integral skylights within a mono-slope roof which pitches to the West. The project will feature a retention pond on the North end of the property for onsite storm water storage. The existing parking lot will be pulverized and resurfaced with additional asphalt parking areas being constructed on the north

KRONES, INC.
9600 South 58th Street
P.O. Box 321801
Franklin, WI 53132-6241

Phone: (414) 409-4000
Fax: (414) 409-4100
Internet: www.kronesusa.com

- 1 -

Franklin
DEC 19 2017
City Development



and south portions of the existing lot. The building will fill an important need for the operations of this international company. The building's intended purpose is to both host prospective and current consumers, introducing them to Krone's line of industry leading equipment and to host international trainees, giving them a single location to both demonstrate and learn to operate and maintain Krone's proprietary equipment.

Revised Franklin Ordinance Language Suggestion Per City Staff Recommendation:

SECTION 15-5.0205 OFF-STREET LOADING REQUIREMENTS

Off-street loading spaces accessory to designated uses shall be provided as follows:

A. Location. All required loading spaces shall be located on the same lot as the use served. No permitted or required loading space shall be located within forty (40) feet of the nearest point of intersection of any two (2) streets. No loading space shall be located in a required side yard abutting a residential zoning district, residential portion of a PDD District, or a required front yard.

B. Access. Each required off-street loading space shall be designed with appropriate means of vehicular access to a street or alley in a manner which will least interfere with traffic movement. Loading spaces on lots located adjacent to public ways shall be so situated as to enable the vehicles to back into the loading dock from areas other than public ways, *unless as otherwise approved by the Plan Commission per subsection 15-5.0205F*. The blocking of loading spaces by other spaces, permanent or moveable structures of any type, including trash receptacles or compactors, shall be prohibited.

C. Surfacing. All open off-street loading spaces shall be improved with pavement and storm water drainage facilities in accordance with such standards set forth in Section 15-5.0202 of this Ordinance.

D. Computation. Where the total floor area of the use being served is less than two thousand (2,000) square feet, the required off-street loading spaces may be used to satisfy the requirements for any off-street parking spaces. Employee parking maneuver areas may also be used for access to loading docks and as truck standing areas.

E. Repair and Service. No motor vehicle repair work or service of any kind shall be permitted in conjunction with loading facilities provided in any residential or nonresidential zoning districts.

F. Maneuvering Space Required to Service Outdoor Loading Areas. Adequate off-street truck maneuvering area shall be provided on-site and not within any public street right-of-way or other public lands, *except as may be allowed by the Plan Commission for properties located within the M-1, M-2 and BP Districts where permanently dead-ended streets and cul-de-sacs may serve as off-street truck maneuvering when the Plan Commission has considered the number of proposed loading docks, the proposed use and frequency of loading and unloading and the number of businesses located on the dead-end street or cul-de-sac and has determined that the adjacent businesses will not be adversely impacted or affected.*



G. Interference With Fire Exit or Emergency Access Prohibited. Off-street loading facilities shall be designed so as not to interfere with any fire exits or emergency access facilities to either a building or site.

SECTION 15-5.0206 OFF-STREET LOADING SPACE DESIGN

A. Minimum Required Off-Street Loading Spaces Accessory to Nonresidential Uses in Business and Public and Semi-Public Districts. The minimum number of required off-street loading spaces accessory to nonresidential uses in the B-1, B-2, B-3, B-4, B-5, B-6, CC, VB, I-1 and P-1 Districts shall be one (1) loading space for buildings containing ten thousand (10,000) to one hundred thousand (100,000) square feet of gross floor area, plus one (1) additional loading space for each additional one hundred thousand (100,000) square feet of gross floor area or shall be ten (10) feet in width and twenty-five (25) feet in length, exclusive of aisle and maneuvering space, and it shall have a vertical clearance of not less than fifteen (15) feet.

B. Minimum Required Off-Street Loading Spaces Accessory to Nonresidential Uses in Industrial Districts. The minimum number and size of off-street loading spaces accessory to uses in the M-1, M-2, and BP Districts shall be in accordance with Table 15-5.0206. For each additional one hundred thousand (100,000) square feet of gross floor area, or fraction thereof, over one hundred thousand (100,000) square feet of gross floor area, one (1) additional loading space shall be provided. Such additional space shall be a minimum of twelve (12) feet in width by fifty (50) feet in length, and have a vertical clearance of not less than fifteen (15) feet. *Loading spaces on lots located on public ways shall be so situated as to enable the vehicles to back into the loading dock from areas other than the public way.*

Best regards

Best regards

Tom Schulz
Vice President
Head of Manufacturing

Krones LCS Center, North America

Direct: 414-409-4210
Cell: 414-526-7166
Email: t.schulz@kronesusa.com

Attachments:
Proposed Site Plan

FRANKLIN ZONING DISTRICT: M1 (Limited Industrial)

- The front (east) required setback is 30 feet
- The side (north and south) required setbacks are 20 feet
- The back (west) required setback is 15 feet
- 40% green space must be maintained (entire parcel)
- Parking - Light Industrial (2 / 1,000sf = 80 spaces required)
- Building plus Loading Dock 42,454 sf
- Paving 63,084 sf
- TOTAL NON-PERVIOUS 105,538 sf
- Site Size Legal Description (Gross) 199,277 sf (4.5748 acres)
- Build-able Site Area (Net) 155,199.47 sf
- TOTAL GREEN SPACE 93,739 sf
- Landscape Ratio (LSR) 47.03 % (11 / 9)
- Gross Floor Area Ratio (GFAR) 21.35 % (6 / 9)
- Net Floor Area Ratio (NFAR) 27.35 % (6 / 10)
- Snow Storage 6,300 sf (10% of paving)

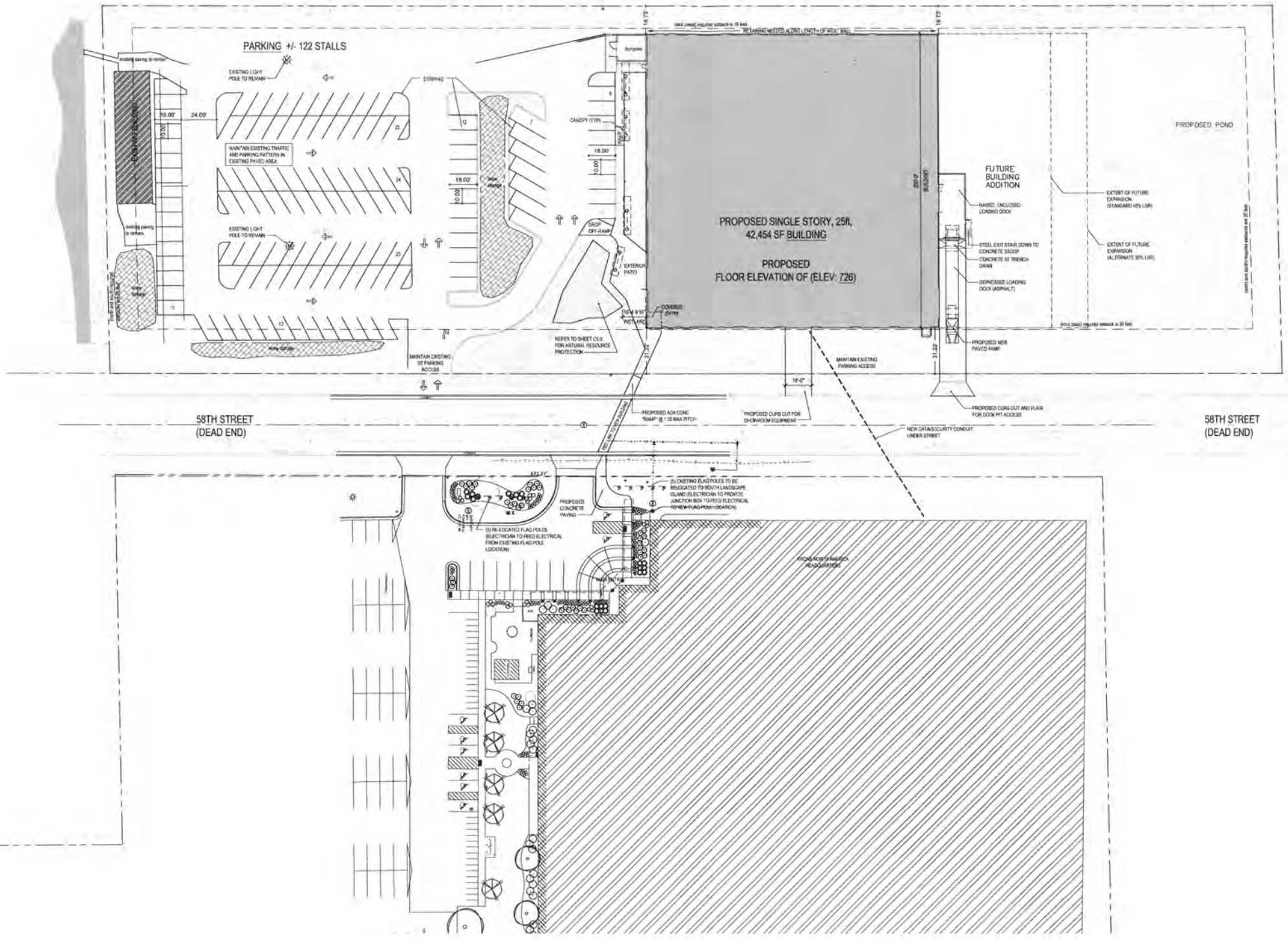

REFER TO LANDSCAPE PLAN FOR ITEMS SPECIFIC TO LANDSCAPING

REFER TO CIVIL SHEETS FOR:

- C1.8 SITE GRADING PLAN / DETAILS
- C2.5 SITE UTILITY PLAN
- C3.5 EROSION CONTROL PLAN

REVISIONS

ANDERSON-ASHTON, INC. DESIGN / BUILD
 7700 South 160th Street
 Omaha, NE 68131
 Phone: (402) 426-1111
 Fax: (402) 426-1112
 www.anderson-ashton.com

IA

Wisconsin Registered Architect
 Steven L. Wagner, Architect
 Wis. DSPS Lic. A-9577-5

Wisconsin Registered Contractor
 ID # 168811 W Dept of Commerce

FRANKLIN, WI 53132

PROPOSED BUILDING FOR:
KRONES, INC
 5611 S 58TH STREET

DATE: 11/27/2017
 PROJECT: AS1
 SHEET: 1 OF 1
 DESIGN NO: 1706
 CONSTRUCTION NO: P-0101

AS1

11/27/2017 10:21:40 AM



CITY OF FRANKLIN



REPORT TO THE PLAN COMMISSION

Meeting of January 4, 2018

Special Use

RECOMMENDATION: City Development Staff recommends approval of the proposed Special Use for a building maintenance services not elsewhere classified (professional home cleaning service business) use and associated site changes upon property located at 11113 W. Forest Home Avenue, subject to the conditions of approval in the attached draft resolution.

Project Name: Molly Maid Special Use

Project Address: 11113 West Forest Home Avenue, Suite 200

Applicant: R & R Swan Investments, LLC

Owners (property): 11113 West Forest Home Avenue, LLC

Current Zoning: M-1 Limited Industrial District & C-1 Conservancy District

2025 Comprehensive Master Plan Industrial

Use of Surrounding Properties: WE Energies substation and Ewald automobile dealership to the north, gasoline service station to the south, Ewald Truck Center and Hiller Ford automobile dealership to the east and single-family residential to the west.

Applicant Action Requested: Recommendation of approval for the proposed Special Use for Molly Maid of Southern Milwaukee County to operate at 11113 West Forest Home Avenue, Suite 200.

INTRODUCTION:

On October 5, 2017, Joel Cook of Ogden Construction submitted a Special Use application on behalf of R & R Swan Investments, LLC dba Molly Maid of Southern Milwaukee County, requesting approval to operate a professional home cleaning service business within the Falcon Commons building located at 11113 West Forest Home Avenue. The proposed use corresponds to Standard Industrial Classification (SIC) Title No. 7349 Building Maintenance Services, Not Elsewhere Classified, which is allowed within the M-1 Limited Industrial District as a Special Use.

At the November 9, 2017 Plan Commission meeting, following a properly noticed public hearing, the following action was approved: move to postpone and continue the Public hearing to the December 7, 2017 Plan Commission meeting. It can be noted that the property owner had still been working on a revised set of plans and associated information in response to staff's initial review comments, and had not submitted any materials for the Plan Commission meeting.

At the December 7, 2017 Plan Commission meeting, the public hearing was held, no one spoke on the matter, and the hearing was closed. Although included within the Plan Commission packets, as Ogden Construction did not submit revised plans until November 30th, staff did not

have sufficient time to conduct a thorough review. The Plan Commission subsequently moved to “table [this matter] to the January 4, 2018 Plan Commission meeting.”

HISTORY:

Molly Maid of Southern Milwaukee County has been operating at 11113 West Forest Home Avenue, Suite 200, since the summer of 2017 without any approvals from the City of Franklin. In order to address this situation, staff has been working with R & R Swan Investments, LLC on obtaining Special Use approval.

This Special Use application also includes a request by the property owner to keep site improvements made without City approvals. Specifically, the parking lot in the northwest corner of the property was reconfigured and a new 15,120 square foot paved parking area was added in the rear of the property.

The applicant’s responses to the Special Use Standards and Regulations form are attached.

In addition, some of the terms and conditions from the prior Special Use approval for the subject property (for Ogden Construction Group LLC as set forth in Ordinance 2015-7065), have yet to be addressed, as noted later in this staff report.

PROJECT DESCRIPTION AND ANALYSIS:

The applicant has indicated that they currently occupy the building, utilize the parking lot in the rear of the property for approximately 12 company cars (and employee parking during working hours), but have made no building or site changes. However, staff has the following concerns as noted below.

Site Plan:

Comparison of the attached Site Development Plan to the previously approved plan in 2015 (as well as a comparison of historic aerial photographs with recent site visits) indicates that the property owner has, without City approvals: reconfigured the parking lot at the northwest corner of the property; added an approximately 15,000 square foot paved parking area in the central portion of the property within the WEPCO easement; and paved the previously graveled area immediately behind (east of) the existing building. While staff has no objection to the changes to the parking lot at the northwest corner of the property and to the parking area immediately behind the building, staff has numerous concerns about the large paved parking area within the WEPCO easement. This will be discussed in greater detail in the Parking and Stormwater sections of this report.

In a related matter, it must be noted that a number of site plan related conditions of the City’s Special Use approval for Ogden Construction in 2015 (Ordinance 2015-7065) have still not been met. These include:

- Condition #1: Pursuant to the approved plans, a 6’ wooden fence was proposed along the east and south sides of the northwestern parking lot.

- Instead, the property owner installed a chain link fence with slats. Pursuant to the approved plans and Section 15-3.0803F. of the UDO (as this screens an open storage area from public view from W. Forest Home Avenue), staff recommends that the property owner shall replace the existing chain link fence along the east and south sides of the northwestern parking lot with a 6' high solid wood fence, for Department of City Development approval, within 90 days of this approval, or prior to the issuance of any Occupancy Permit, whichever may occur first.
- Condition #4: “An architectural elevation of the 10’ x 10’ wood fence dumpster enclosure shall be submitted to the Department of City Development for review and approval by Staff, prior to issuance of a Building Permit.”
 - While an elevation was provided, the wooden dumpster enclosure was not constructed. In addition, Section 15-3.0803I. of the UDO requires dumpster enclosures to consist of sight proof fencing (wood or masonry) and landscaping, unless waived by the Plan Commission. As this area is area is partially visible from adjacent properties and an enclosure was required of the prior Special Use approval, staff recommends that the property owner shall install a 10' high sight proof wooden dumpster enclosure, for Department of City Development approval, within 90 days of this approval, or prior to issuance of any Occupancy Permit, whichever may occur first.

It can also be noted that the dumpsters are currently located within the WEPCO easement, and as a condition of approval for location of the paved parking lot within this easement, the American Transmission Company (ATC) has requested that no structures or dumpsters be located within the easement. Therefore, staff recommends that the property owner shall relocate the dumpsters immediately to the east of the WEPCO easement near the southern boundary of the subject property, for Department of City Development approval, within 90 days of this approval, or prior to issuance of any Occupancy Permit, whichever may occur first.

A trailer, apparently over 8,000 lbs, is parked at the rear of the property and is used for storage. As this requires prior City approval pursuant to Section 15-5.0202G.3. of the UDO, and as this was not included within the property owner’s application materials nor indicated within the public hearing notice, staff recommends that the property owner shall remove the trailer and any other commercial vehicles over 8,000 lbs, for Department of City Development approval, within 90 days of this approval, or prior to issuance of any Occupancy Permit, whichever may occur first.

Stormwater Management:

It must be noted that a stormwater related condition of the City’s Special Use approval for Ogden Construction in 2015 (Ordinance 2015-7065) has still not been met.

- Condition #8: “Applicant shall have the stormwater drainage pipe televised to assess its current condition, provide the results of the inspection to the Engineering Department together with a location map, repair the pipe as may be necessary, and grant the City of Franklin an easement to protect and access the pipe.”
 - In response, the property owner has only identified the location of the manholes associated with the storm sewer, and has drawn a straight line between those two

points. As this condition has still not been addressed, *staff recommends that the property owner shall have the stormwater drainage pipe televised to assess its current condition, provide the results of the inspection to the Engineering Department together with a location map, repair the pipe as may be necessary, and grant the City of Franklin an easement to protect and access the pipe, prior to June 1, 2018.*

As previously noted, the property owner has constructed a paved parking area without City approvals. Although the owner states that this was located within a previously graveled area, staff partially disagrees, based upon review of historic aerial photographs and current site conditions. Staff also disagrees with the property owner's calculations of pervious and impervious areas. Therefore, *staff recommends that the property owner shall prepare a stormwater management plan pursuant to Section 15-7.0103 of the UDO, for Engineering Department review and approval, within 90 days of this approval, or prior to issuance of any Occupancy Permit, whichever may occur first.*

Although the subject parking lot has already been constructed, grading, filling, and/or other land disturbing activities has occurred which could impact site drainage. In addition, as noted in the parking section of this report, additional land disturbing activities are recommended by staff. As such, *staff recommends that the property owner shall prepare a Grading/Drainage/Erosion Control Plan for Engineering Department review and approval, within 90 days of this approval, or prior to issuance of any Occupancy Permit, whichever may occur first.*

Parking:

Pursuant to the current uses within the subject building, and the parking standards contained within the UDO, 45 parking spaces are required. However, the subject property provides 83 parking spaces, or 38 spaces or about 84 percent more than required. While Section 15-5.0203 of the UDO allows parking increases above 10% of the standard parking ratio, with the submittal of reasonably sufficient proof that additional parking is needed, staff does not believe that sufficient information has been submitted. In particular, it can be noted that Molly Maid, who the paved parking area may have been primarily constructed for, only requires approximately 37 spaces, while the paved parking area provides 56 parking spaces. Therefore, *staff recommends that the property owner shall remove approximately 20 parking spaces, and restore the area to turf lawn, for Department of City Development review and approval, prior to June 1, 2018.* Staff would note that removal of such parking, and restoration to a grassy surface, may benefit the stormwater management plan from the standpoint of the amount of impervious surface and the sizing of any required stormwater facilities.

Pursuant to Section 15-5.0202E. of the UDO, *staff recommends that the property owner shall install curb and gutter for the recently paved parking area, for Engineering Department review and approval, prior to June 1, 2018.* It can be noted that the UDO does allow the Plan Commission to waive this requirement for additions to existing structures located in areas without a predominance of curb and gutter. However, as this parking area is not due to a building addition, is separate from the existing paved parking areas, and such installation could potentially benefit site drainage/stormwater efforts, staff would continue to recommend that curb and gutter be installed at this time.

Landscaping:

Although the property owner has paved an additional parking area, the owner has not prepared a revised landscape plan, nor verified the minimum required Landscape Surface Ratio pursuant to that plan, nor installed any additional plantings for the additional parking spaces. Therefore, staff recommends that the property owner shall prepare a Landscape Plan pursuant to Divisions 15-5.0300 and 15-7.0300 of the UDO, for review and approval by the Department of City Development, within 90 days of this approval, or prior to issuance of any Occupancy Permit, whichever may occur first. Staff further recommends that the property owner shall install all required landscaping prior to June 1, 2018.

Natural Resource Protection Plan:

It can be noted that C-1 Conservancy District zoning is located on the far eastern portion of the subject property, and that a Natural Resource Protection Plan has not been prepared for the subject property. However, the City does have on file a letter from R.A. Smith National Inc. dated 2011 that indicates there are no protected natural resource features within the subject property. Although site changes were not proposed within the eastern half of the property in the 2015 Special Use request, the property owner has since constructed a paved parking area approximately 50' from the C-1 zoning district. Therefore, *staff suggests that the property owner prepare a Natural Resource Protection Plan for Department of City Development review and approval.* Furthermore, should it be determined that no natural resources are present, *staff suggests that the property owner apply for a rezoning to remove the C-1 zoning district from the subject property.*

Signage:

The applicant and the property owner have indicated that no new signage is proposed, and have been advised that any signage will require separate review and approval by the Architectural Review Board and issuance of a Sign Permit from the Inspection Department.

STAFF RECOMMENDATION:

Due to the fact that the property owner has not completed all of the conditions associated with the 2015 Special Use approval, as the property owner had constructed a parking lot without City approvals, as a number of related conditions are proposed in the current Special Use request, and pursuant to Sections 15-3.0701D. and E. of the UDO (regarding Conditions on Special Use Permits), and Section 15-7.0105 of the UDO (regarding Site Plan improvements), staff recommends that the property owner shall provide an appropriate financial surety to guarantee that improvements including improved off-street parking, open space areas, utilities, and landscaping will be completed on schedule, for Department of City Development and Engineering Department review and approval within 60 days of this approval, or prior to issuance of any Occupancy Permit, whichever may occur first.

City Development Staff recommends approval of the proposed Special Use for a building maintenance services not elsewhere classified (professional home cleaning service business) use and associated site changes upon property located at 11113 W. Forest Home Avenue, subject to the conditions of approval in the attached draft resolution.

RESOLUTION NO. 2017-_____

A RESOLUTION IMPOSING CONDITIONS AND RESTRICTIONS
FOR THE APPROVAL OF A SPECIAL USE FOR A PROFESSIONAL HOME
CLEANING SERVICE BUSINESS USE AND PROPERTY OWNER REQUESTED
REVISED SITE PLAN APPROVAL UPON PROPERTY LOCATED
AT 11113 WEST FOREST HOME AVENUE, SUITE 200
(R & R SWAN INVESTMENTS, LLC, D/B/A MOLLY MAID, APPLICANT)

WHEREAS, R & R Swan Investments, LLC, d/b/a Molly Maid, having petitioned the City of Franklin for the approval of a Special Use within an M-1 Limited Industrial District and C-1 Conservancy District under Standard Industrial Classification Title No. 7349 “Building Cleaning and Maintenance Services, Not Elsewhere”, to allow for a maid service business use, with hours of operation from 7:00 a.m. to 5:00 p.m., Monday through Friday, which application also includes a property owner requested revised Site Plan approval for existing site improvements constructed without prior City approval, specifically, reconfiguration of the parking lot in the northwest corner of the property and addition of a new parking lot in the rear of the property, upon property located at 11113 West Forest Home Avenue, Suite 200, bearing Tax Key No. 704-9978-002, more particularly described as follows:

Parcel 1 of Certified Survey Map No. 3988, recorded on March 11, 1981, Reel 1362, Images 185 to 187, as Document No. 5462366, being a part of the Northeast 1/4 of Section 6, Town 5 North, Range 21 East, in the City of Franklin, County of Milwaukee, State of Wisconsin; and

WHEREAS, such petition having been duly referred to the Plan Commission of the City of Franklin for a public hearing, pursuant to the requirements of §15-9.0103D. of the Unified Development Ordinance, and a public hearing having been held before the Plan Commission on the 9th day of November, 2017 and continued on the 7th day of December 2017, and the Plan Commission thereafter having determined to recommend that the proposed Special Use and revised site plan be approved, subject to certain conditions, and the Plan Commission further finding that the proposed Special Use and revised site plan upon such conditions, pursuant to §15-3.0701 of the Unified Development Ordinance, will be in harmony with the purposes of the Unified Development Ordinance and the Comprehensive Master Plan; that it will not have an undue adverse impact upon adjoining property; that it will not interfere with the development of neighboring property; that it will be served adequately by essential public facilities and services; that it will not cause undue traffic congestion; and that it will not result in damage to property of significant importance to nature, history or the like; and

R & R SWAN INVESTMENTS, LLC, /D/B/A MOLLY MAID – SPECIAL USE
RESOLUTION NO. 2017-_____

Page 2

WHEREAS, the Common Council having received such Plan Commission recommendation and also having found that the proposed Special Use and revised site plan, subject to conditions, meets the standards set forth under §15-3.0701 of the Unified Development Ordinance.

NOW, THEREFORE, BE IT RESOLVED, by the Mayor and Common Council of the City of Franklin, Wisconsin, that the petition of R & R Swan Investments, LLC, d/b/a Molly Maid, for the approval of a Special Use and revised site plan for the property particularly described in the preamble to this Resolution, be and the same is hereby approved, subject to the following conditions and restrictions:

1. That this Special Use and revised site plan is approved only for the use of the subject property by R & R Swan Investments, LLC, d/b/a Molly Maid, successors and assigns, as a maid service business use, which shall be developed in substantial compliance with, and operated and maintained by R & R Swan Investments, LLC, d/b/a Molly Maid, pursuant to those plans City file-stamped November 30, 2017 and annexed hereto and incorporated herein as Exhibit A.
2. R & R Swan Investments, LLC, d/b/a Molly Maid, successors and assigns, shall pay to the City of Franklin the amount of all development compliance, inspection and review fees incurred by the City of Franklin, including fees of consults to the City of Franklin, for the R & R Swan Investments, LLC, d/b/a Molly Maid maid service business, within 30 days of invoice for same. Any violation of this provision shall be a violation of the Unified Development Ordinance, and subject to §15-9.0502 thereof and §1-19. of the Municipal Code, the general penalties and remedies provisions, as amended from time to time.
3. The approval granted hereunder is conditional upon R & R Swan Investments, LLC, d/b/a Molly Maid and the maid service business use for the property located at 11113 West Forest Home Avenue, Suite 200: (i) being in compliance with all applicable governmental laws, statutes, rules, codes, orders and ordinances; and (ii) obtaining all other governmental approvals, permits, licenses and the like, required for and applicable to the project to be developed and as presented for this approval.
4. The property owner shall replace the existing chain link fence along the east and south sides of the northwestern parking lot with a 6' high solid wood fence, for Department of City Development approval, within 90 days of this approval or prior to the issuance of any Occupancy Permit whichever may occur first.

5. The property owner shall install a 10' high sight proof wooden dumpster enclosure, for Department of City Development approval, within 90 days of this approval or prior to issuance of any Occupancy Permit whichever may occur first.
6. The property owner shall relocate the dumpsters immediately to the east of the WEPCO easement near the southern boundary of the subject property, for Department of City Development approval, within 90 days of this approval or prior to issuance of any Occupancy Permit whichever may occur first.
7. The property owner shall remove the trailer and any other commercial vehicles over 8,000 lbs, for Department of City Development approval, within 90 days of this approval or prior to issuance of any Occupancy Permit whichever may occur first.
8. The property owner shall have the stormwater drainage pipe televised to assess its current condition, provide the results of the inspection to the Engineering Department together with a location map, repair the pipe as may be necessary, and grant the City of Franklin an easement to protect and access the pipe, prior to June 1, 2018.
9. The property owner shall prepare a stormwater management plan pursuant to Section 15-7.0103 of the UDO, for Engineering Department review and approval, within 90 days of this approval or prior to issuance of any Occupancy Permit whichever may occur first.
10. The property owner shall prepare a Grading/Drainage/Erosion Control Plan for Engineering Department review and approval, within 90 days of this approval or prior to issuance of any Occupancy Permit whichever may occur first.
11. The property owner shall remove approximately 20 parking spaces, and restore the area to turf lawn, for Department of City Development review and approval, prior to June 1, 2018.
12. The property owner shall install curb and gutter for the recently paved parking area, for Engineering Department review and approval, prior to June 1, 2018.
13. The property owner shall prepare a Landscape Plan pursuant to Divisions 15-5.0300 and 15-7.0300 of the UDO, for review and approval by the Department of City Development, within 90 days of this approval or prior to issuance of any Occupancy Permit whichever may occur first.
14. The property owner shall install all required landscaping prior to June 1, 2018.

15. The property owner shall provide an appropriate financial surety to guarantee that improvements including improved off-street parking, open space areas, utilities, and landscaping will be completed on schedule, for Department of City Development and Engineering Department review and approval within 60 days of this approval or prior to issuance of any Occupancy Permit whichever may occur first

16. [other conditions, etc.]

BE IT FURTHER RESOLVED, that in the event R & R Swan Investments, LLC, d/b/a Molly Maid, successors or assigns, or any owner of the subject property, does not comply with one or any of the conditions and restrictions of this Special Use and revised site plan Resolution, following a ten (10) day notice to cure, and failure to comply within such time period, the Common Council, upon notice and hearing, may revoke the Special Use and revised site plan permission granted under this Resolution.

BE IT FURTHER RESOLVED, that any violation of any term, condition or restriction of this Resolution is hereby deemed to be, and therefore shall be, a violation of the Unified Development Ordinance, and pursuant to §15-9.0502 thereof and §1-19. of the Municipal Code, the penalty for such violation shall be a forfeiture of no more than \$2,500.00, or such other maximum amount and together with such other costs and terms as may be specified therein from time to time. Each day that such violation continues shall be a separate violation. Failure of the City to enforce any such violation shall not be a waiver of that or any other violation.

BE IT FURTHER RESOLVED, that this Resolution shall be construed to be such Special Use Permit as is contemplated by §15-9.0103 of the Unified Development Ordinance.

BE IT FURTHER RESOLVED, pursuant to §15-9.0103G. of the Unified Development Ordinance, that the Special Use and revised site plan permission granted under this Resolution shall be null and void upon the expiration of one year from the date of adoption of this Resolution, unless the Special Use has been established by way of the issuance of an occupancy permit for such use.

BE IT FINALLY RESOLVED, that the City Clerk be and is hereby directed to obtain the recording of a certified copy of this Resolution in the Office of the Register of Deeds for Milwaukee County, Wisconsin.

Introduced at a regular meeting of the Common Council of the City of Franklin this _____ day of _____, 2017.

R & R SWAN INVESTMENTS, LLC, /D/B/A MOLLY MAID – SPECIAL USE
RESOLUTION NO. 2017-_____

Page 5

Passed and adopted at a regular meeting of the Common Council of the City of Franklin this _____ day of _____, 2017.

APPROVED:

Stephen R. Olson, Mayor

ATTEST:

Sandra L. Wesolowski, City Clerk

AYES _____ NOES _____ ABSENT _____

11113 W. Forest Home Ave.
TKN: 704 9978 002



Planning Department
(414) 425-4024

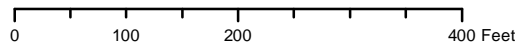

This map shows the approximate relative location of property boundaries but was not prepared by a professional land surveyor. This map is provided for informational purposes only and may not be sufficient or appropriate for legal, engineering, or surveying purposes.

11113 W. Forest Home Ave.
TKN: 704 9978 002

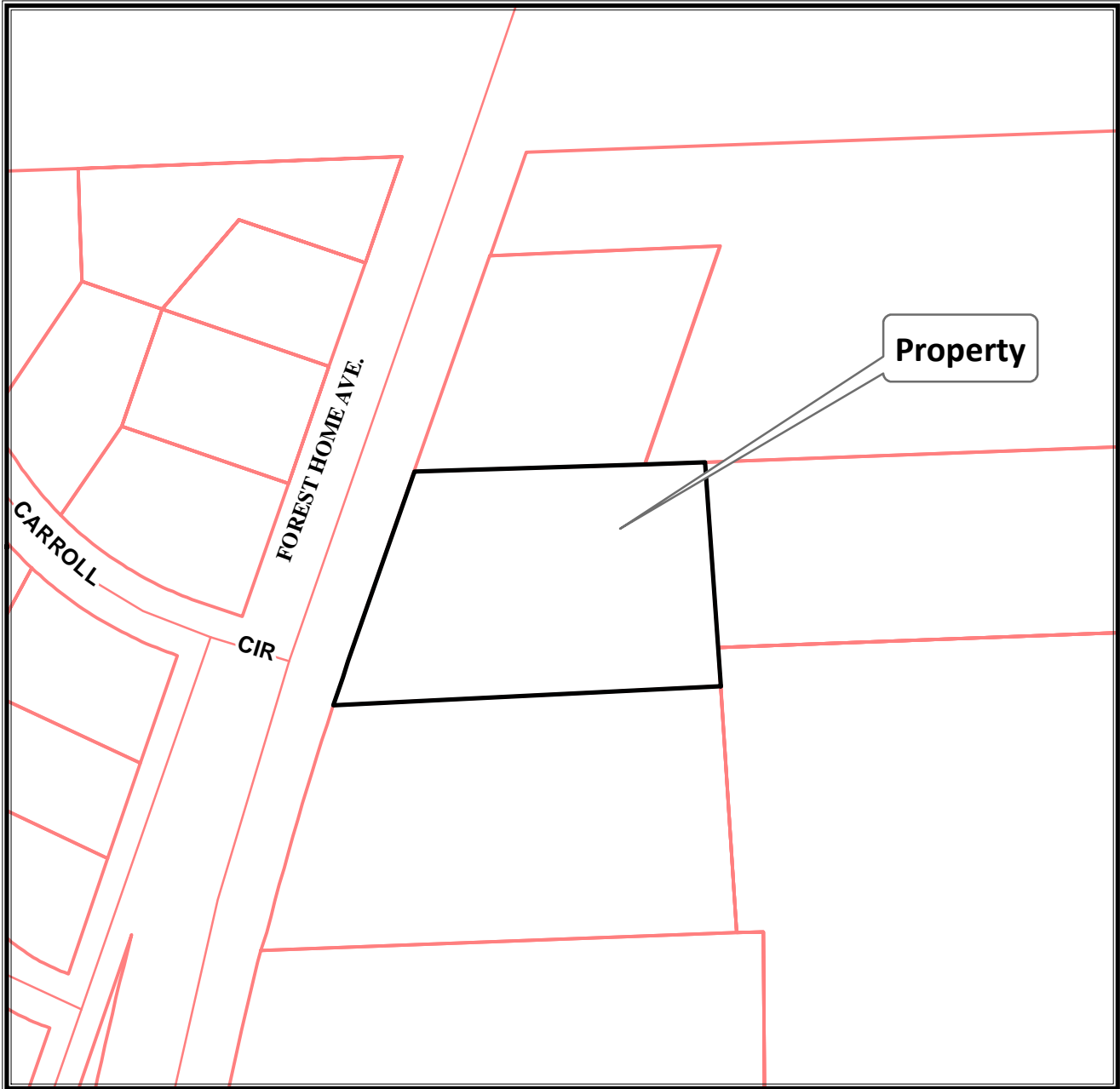

Planning Department
(414) 425-4024

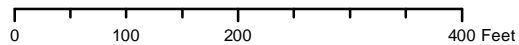

This map shows the approximate relative location of property boundaries but was not prepared by a professional land surveyor. This map is provided for informational purposes only and may not be sufficient or appropriate for legal, engineering, or surveying purposes.





April 7, 2017 Aerial

City of Franklin

Department of City Development

Date: October 19, 2017
To: Joel Cook, Ogden Construction
From: Department of City Development
RE: Molly Maid Special Use – Staff Comments

Please be advised that City Staff has reviewed the above application. Department comments are as follows for the Molly Maid of Southern Milwaukee County Special Use Application City file-stamped October 5, 2017.

Unified Development Ordinance (UDO) Requirements

Site Plan

1. Please indicate the owner's and/or developer's name and address on the site plan per Section 15-7.0103-B of the UDO. *The property owner is 11113 W. Forest Home Avenue, LLC.*
2. Please indicate the width of all right-of-ways and label "ROW" as required by Section 15-7.0103-L of the UDO.
3. Please indicate on the site plan all existing and proposed storm sewers per Section 15-7.0103-O of the UDO. *Three (3) Notes on the Site Plan state, "Unkown location of storm sewer line". Condition No. 8 of Resolution No. 2015-7065 states, "Applicant shall have the stormwater drainage pipe televised to assess its current condition, provide the results of the inspection to the Engineering Department together with a location map, repair the pipe as may be necessary, and grant the City of Franklin an easement to protect and access the pipe, prior to the issuance of a Final Occupancy Permit". It doesn't appear this condition was ever satisfied. Therefore, Staff recommends this be completed within 30 days of Special Use approval.*
4. Please submit a storm water management plan per Section 15-7.0103-P of the UDO. This plan should include the location of any proposed storm water management facilities, including detention/retention areas and the submission of storm water calculations.
5. Please provide a landscape plan per Section 15-7.0103(R) and 15-7.0300 which illustrates your existing and proposed plantings.
6. If new lighting is proposed, please provide a lighting plan per Section 15-7.0103(W) of the UDO. Lighting standards can be found in Division 15-5.0400 of the UDO. *Was any exterior lighting adding as part of the parking lot site work?*
7. Please indicate the existing zoning of the property on the site plan per Section 15-7.0103-Z of the UDO. *Specifically, please add the boundary of the C-1 Conservancy District to the Site Plan so Staff can determine whether or not the parking lot improvements are outside of the C-1 District. Please also see comment No. 16.*

Staff Recommendations

Site Plan

1. Please indicate the width of the north driveway on the site plan.
2. The site plan depicts a 10' x 10' wood fence dumpster enclosure, which was never installed. There are currently two unscreened dumpsters in the rear of the property along the south lot line. Staff recommends installing an enclosure large enough to house both dumpsters currently onsite.
3. Condition No. 1 of Resolution No. 2015-7065 stated that Ogden's commercial contractor business use was to be developed in substantial compliance with, and operated and maintained pursuant to those plans City file-stamped January 26, 2015. Those plans depicted a 6' wood fence being installed along the east and south sides of the parking lot on the northwest portion of the site. However, it appears a chain-link fence with slats was installed instead. According to Section 15-3.0803(F) of the UDO, open storage areas are to be screened with a solid wooden fence at least six (6) feet in height. Therefore, Staff recommends the chain-link fence be replaced with a solid 6-foot wood fence.
4. The total impervious surface area is stated on the face of the Site Plan. However, please verify the minimum Landscape Surface Ratio of the M-1 District of 0.4 or 40% is being met.
5. Please depict the cross-access to the property to the south at 11123 W. Forest Home Ave., located in the rear of the property.

Landscape Plan

6. Staff recommends installing the minimum number of standard plant units per Section 15-5.0302 of the UDO to accompany the new parking lot.

Commercial, Office, Institutional and Similar Uses

<u>Type</u>	<u>Planting Size</u>	<u>Minimum Quantity</u>
Canopy/Shade Tree	2.5 inch caliper	1 per 5 provided parking spaces
Evergreens	4 feet tall	1 per 5 provided parking spaces
Decorative Trees	1.5 inch caliper	1 per 5 provided parking spaces
Shrubs	3 feet tall	1 per 5 provided parking spaces

7. Coordinate the Planting list with like types and designate the plants as a Canopy, Evergreen, Decorative Tree or Shrub. Please indicate the required amount of plantings in accordance with Section 15-5.0302 A. of the UDO within the Planting List.
8. Staff recommends the additional landscape plantings be installed within the parking setback along the north property line and within the C-1 District along the east property line. These areas may need topsoil added for anything to successfully grow.

Parking

8. Please depict the Parking setback from the north property line to the new parking lot in the rear of the property. Staff recommends a minimum off-street parking setback of 10-feet be provided in accordance with Section 15-5.0202C.4 of the UDO.
9. Staff recommends curb and gutter for the new parking lot in the rear of the property per Section 15-5.0202E of the UDO.
10. Staff recommends providing evidence that a parking increase above 10% of the Standard Parking Ratio should be approved. According to Section 15-5.0203B. of the UDO, Potential

Parking Increase Considerations (above 10% or 5 spaces of the Standard Parking Ratio) include:

1. For on-site parking, the applicant submits reasonably sufficient proof that the maximum number of required parking spaces would be insufficient for the proposed use's projected parking demand. Evidence may include, but not limited to, parking standard comparisons and/or comparisons of parking demand for existing similar uses.
2. For on-site queuing, the applicant provides reasonably sufficient proof that additional vehicle stacking space is needed to prevent interference with roadways, parking lot circulation or pedestrian safety.
3. For on-site parking, the applicant submits reasonably sufficient proof that there are no reasonable opportunities to share parking within or adjacent to the site.
4. For on-site parking, the applicant submits reasonably sufficient proof of a greater need for handicapped accessible parking spaces, while still needed to provide sufficient standard parking spaces.

Sign Plan

11. Please note any proposed signage will require separate review and approval by the Architectural Review Board and issuance of a Sign Permit from the Inspection Department.

Project Summary

12. In lieu of a page that states, "This project will change nothing on the exterior of the building they are taking the space as-is", please provide a summary of the improvements made including when and why they were made.
13. A semi-trailer and other commercial vehicles weighing over 8,000 lbs rated gross vehicle weight are currently being parked in the rear of the property over-night. According to Section 15-5.0202G.3 of the UDO, Therefore, Staff recommends this Special Use Application include a request to park vehicles over 8,000 lbs rated gross vehicle weight on the property overnight. Please specify the type of vehicles, the number of vehicles and depict where they will be parked.
14. Please state the costs of the subject site improvements.

Other

15. Please submit a letter from the easement owner indicating approval of site improvements within the 120' Wide W.E.P.C.O. Easement. Please contact Tony Marciniak with ATC at (262) 506-6700 or tmarciniak@atcllc.com for such an approval.
16. Staff recommends removing all outdoor storage/vehicles from the portion of the property zoned C-1 Conservancy District.

Engineering Department Comments

17. Was/will any grading done/be done to the site? If so, a Grading and Erosion Control Plan or As-built Grading Plan must be prepared and submitted.
18. It is unclear from what has been submitted just how much impervious area has been/will be added to the site and when. Since the total impervious area on the site is over one-half acre, the following must be submitted to the Engineering Department:

- An aerial from September 2001 (if this cannot be found, then from year 2000). On that aerial you will need to draw/trace as close as possible the existing (at that time) impervious area including gravel (building, driveway, parking, etc.). You will need to find the area (square feet) and clearly note it on the aerial.
- A current plan like the one you submitted that needs to include a survey of all impervious area on the site. The square footage of that area needs to be noted on the exhibit.

When those are submitted, the required storm water management can be determined.

19. City is not approving any improvements in the private easement (120-ft Wide W.E.P. CO.-Easement). WE-Energies must also be informed regarding these improvements.
20. Site plan shows a typo error instead of referencing it to CSM # 3983 it should be #3988.

Fire Department Comments

The Fire Department has no comments/concerns regarding the proposed special use at this location.

Police Department Comments

The Franklin Police Department has reviewed the application for 11113 West Forest Home Ave. The Police Department has no issues with this request.

11113 W. Forest Home Ave.

10.13.17



Blair

guy's small home & car







To whom may concern,

9-20-17

R&R Swan Investments LLC DBA. Molly Maid operates a professional home cleaning service. We operate Monday thru Friday from 7 am. To 5pm. We employ 20 to 25 employees. We have 12 company cars that are parked on the site in a lower parking in the evening. Are employee also park in the lower lot during their working hours. The current location is 11113 W Forest Home Ave Suite 200 Franklin WI. 53132. We took the space as is. No work has been done to our space.

Thank You

Ryan Swan

R&R Swan Investments LLC.

414-427-6100

Franklin

NOV 30 2017

City Development

Molly Maid of Southern Milwaukee County

11113 W. Forest Home Avenue Suite 200 Franklin, WI 53132 Ph: (414)427-6100 swan.rick@sbcglobal.net www.mollymaid.com

November 28, 2017

Orrin Sumwalt
City Plan Commission
City of Franklin
9229 W Loomis Rd
Franklin, WI 53132

RE: Molly Maids

I am writing in response to your staff comments dated 10/19/17.

Site Plan (UDO)

- 1.) owners name & address are on the attached site plan
- 2.) right of way widths are on the attached site plan
- 3.) storm sewer is now shown on the attached site plan
- 4.) storm water management is not required per attached over heads
- 5.) see attached landscape plan previously submitted & approved
- 6.) no new lighting was installed nor proposed
- 7.) see attached site plan showing that the parking lot is not in the C-1 zoning

Site Plan (staff)

- 1.) see attached site plan
- 2.) the (2) dumpsters are screened by the vision slatted fence at the upper parking lot & is not visible from the road- would that be acceptable?
- 3.) Ogden Construction installed 6'-0" high chain link fence with vision slats
- 4.) the site data or attached site plan verifies the surface ratio
- 5.) see attached site plan

- 6.) we feel that because the parking is depressed the landscaping will only be seen by us and will not be seen by any of the neighbors, therefore, we request that the landscape request be waived

- 7.) see #6

Franklin
NOV 30 2017

City Development

8.) see #6

Parking

- 8.) 10' set back was held see attached site plan
- 9.) Per 15-5.0203B of UDO Forest Home Ave does not have curb and gutter, therefore, they are not required
- 10.) The maximum # of parking is not enough due to the fact that Molly Maids has 2-3 people per car. This means 2-3 people have their personal cars as well as the company owned cars will be present for a period in the morning and evening which requires a higher parking load at those times only.

Sign Plan

- 11.) No signage is proposed

Project Summary

- 12.) There were no improvements to the existing building when Molly Maids moved in, however, we did pave an area on the lower tier to accommodate parking in June of 2017.
- 13.) We acquired a semi-trailer from an associate that had no further use for it and we are using it for storage. If this is an issue we will have it removed. No other commercial vehicles weighing over 8000lbs are on the site.
- 14.) Site improvements (paving) cost \$17,942.00

Other

- 15.) Approval from ATC is pending
- 16.) All outdoor storage/vehicles currently in the C-1 area will be removed

Engineering Dept Comments

- 17.) No grading was completed or is anticipated
- 18.) See attached aerials
- 19.) ATC has been informed; see #15
- 20.) Typo has been corrected

If you have any questions, please do not hesitate to call us.

Sincerely,
Ogden Construction Group, LLC

Joel Cook
President

Joel Cook

From: Tony Zanon [tony.zanon@pinnacle-engr.com]
Sent: Tuesday, November 28, 2017 1:36 PM
To: Joel Cook
Subject: Franklin
Attachments: Site plan markup 11-15-17.pdf; 2000 Aerial.pdf

Joel,
Franklin requires storm water management when land disturbance is greater than one acre or the increase in impervious is greater than 0.5 acres. Wisconsin DNR requires storm water management when disturbance is greater than one acre. MMSD is when disturbance is greater than 2 acres or new impervious is greater than 0.5 acres.

In 2000 there was 49,600 +/- SF of impervious. Per the architects site plan the impervious area on site is now 44,200 SF so there is not an increase in impervious area.

See the attached map, I assume you roughly disturbed the area in green when building the parking lot. That area is approximately 24,200 SF (0.56 acres) so there was not land disturbance over one acre. Please confirm the green area is correct.

Storm water management would not be required because you did not increase impervious by 0.5 acres or more and did not disturb over one acre of land.

Tony

Anthony S. Zanon, P.E. | Senior Project Manager



15850 W. Bluemound Road | Suite 210 | Brookfield, WI 53005
(262) 754-8888 Main | (262) 754-0839 Direct | (262) 754-8850 Fax
tony.zanon@pinnacle-engr.com | www.pinnacle-engr.com

PLAN | DESIGN | DELIVER

CONFIDENTIALITY NOTICE:

This message is intended for the use of the individual or entity to which it is addressed and may contain information that is privileged, confidential and/or exempt from disclosure under applicable law. If the reader of this message is not the intended recipient or the employee or agent responsible for delivering this message to the intended recipient, you are hereby notified that any dissemination, distribution or copying of this communication is strictly prohibited. If you have received this communication in error, please notify us immediately by email reply.

Franklin

NOV 30 2017

City Development

MILWAUKEE COUNTY INTERACTIVE MAPPING SERVICE

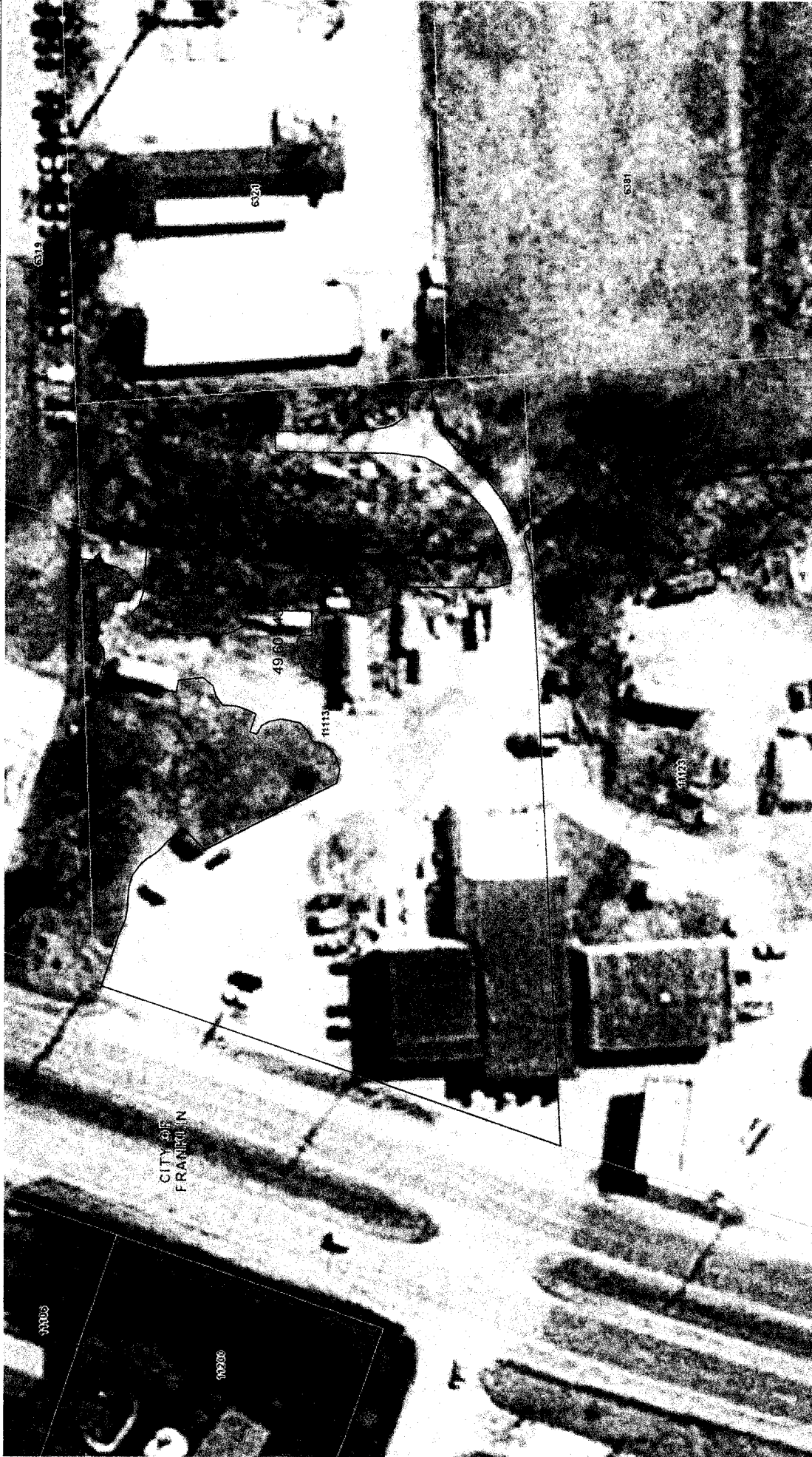

NOTES
2000 AERIAL

DISCLAIMER: This map is user generated static output from the Milwaukee County GIS system. It is not intended for use as a legal document or for reference purposes only and may or may not be accurate, current or otherwise reliable. No liability is assumed for the data delineated herein either expressed or implied by Milwaukee County or its employees.

THIS MAP IS NOT TO BE USED FOR NAVIGATION

1:584

94 Feet

47

0

94

MAD_1927_StatePlane_Wisconsin_South_FIPS_4803
© MCHMILIS

C-1
 DATE: DEC. 1, 2014
 PROJECT NUMBER: 14-005

PROPOSED SITE DEVELOPMENT PLAN & DETAILS

OGDEN CONSTRUCTION REMODEL

1113 W. FOREST HOME AVE.
 SHREVEPORT, LA
 SHEET TITLE:

BUILDING INFO	
PROJECT:	OGDEN CONSTRUCTION CRACK
CLIENT:	OGDEN CONSTRUCTION
ARCHITECT:	1113 W. FOREST HOME AVE. SHREVEPORT, LA 71201
DESIGNER:	1113 W. FOREST HOME AVE. SHREVEPORT, LA 71201
DATE:	12/01/14

SITE DATA	
ZONE:	M1 (C1)
TOTAL AREA:	11,930 S.F.
EXISTING LOT COVER:	7,300 S.F.
EXISTING LOT COVER:	2,630 S.F.
EXISTING LOT COVER:	2,000 S.F.
EXISTING LOT COVER:	1,000 S.F.
EXISTING LOT COVER:	1,000 S.F.
EXISTING LOT COVER:	1,000 S.F.
EXISTING LOT COVER:	1,000 S.F.
EXISTING LOT COVER:	1,000 S.F.
EXISTING LOT COVER:	1,000 S.F.
EXISTING LOT COVER:	1,000 S.F.

PREVIOUSLY APPROVED DATA: 2/6/15

SITE DATA:

LOT AREA: 11,930 S.F.
 EXISTING LOT COVER: 7,300 S.F.
 PROPOSED LOT COVER: 8,500 S.F.
 EXISTING LOT COVER: 2,630 S.F.
 PROPOSED LOT COVER: 2,630 S.F.
 EXISTING LOT COVER: 2,000 S.F.
 PROPOSED LOT COVER: 2,000 S.F.
 EXISTING LOT COVER: 1,000 S.F.
 PROPOSED LOT COVER: 1,000 S.F.
 EXISTING LOT COVER: 1,000 S.F.
 PROPOSED LOT COVER: 1,000 S.F.
 EXISTING LOT COVER: 1,000 S.F.
 PROPOSED LOT COVER: 1,000 S.F.

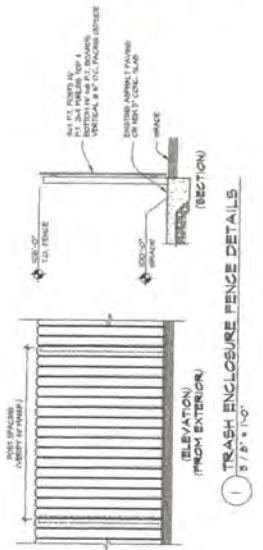

OWNER + developer remove address
 1113 W. FOREST HOME AVE
 SHREVEPORT, LA 71201

Plat C-1 low from original
 that REC sends from Franklin City



SITE DEVELOPMENT PLAN
 1" = 20'-0"

Franklin
 NOV 30 2017
 City Development

1) 104' lower conditions location of stream bank in field REC can pick up
 start station: REC can do case if needed
 54' x 40'
 84' x 118' → 344' x 34'
 194' x 118'
 area implications: 60% → 86118 → 5(8713)'

PATARA
 Excellence in Architecture
 2601 S. Sunny Stage Rd., New Berlin, WI 53151
 Phone: 262-786-6776 Fax: 262-786-7036

DIVISION 15-3.0700 SPECIAL USE STANDARDS AND REGULATIONS

SECTION 15-3.0701 GENERAL STANDARDS FOR SPECIAL USES

A. ***General Standards.*** No special use permit shall be recommended or granted pursuant to this Ordinance unless the applicant shall establish the following:

1. **Ordinance and Comprehensive Master Plan Purposes and Intent.** The proposed use and development will be in harmony with the general and specific purposes for which this Ordinance was enacted and for which the regulations of the zoning district in question were established and with the general purpose and intent of the City of Franklin Comprehensive Master Plan or element thereof.

Response: We will occupy current space at 11113 W. Forest Home Ave. Suite 200, Franklin WI. 53132

2. **No Undue Adverse Impact.** The proposed use and development will not have a substantial or undue adverse or detrimental effect upon or endanger adjacent property, the character of the area, or the public health, safety, morals, comfort, and general welfare and not substantially diminish and impair property values within the community or neighborhood.

Response: We will have no undue adverse impact.

3. **No Interference with Surrounding Development.** The proposed use and development will be constructed, arranged, and operated so as not to dominate the immediate vicinity or to interfere with the use and development of neighboring property in accordance with the applicable zoning district regulations.

Response: We will have no interference with surrounding development.

4. **Adequate Public Facilities.** The proposed use and development will be served adequately by essential public facilities and services such as streets, public utilities including public water supply system and sanitary sewer, police and fire protection, refuse disposal, public parks, libraries, schools, and other public facilities and utilities or the applicant will provide adequately for such facilities.

Response: We will be served by current facilities.

5. **No Traffic Congestion.** The proposed use and development will not cause undue traffic congestion nor draw significant amounts of traffic through residential streets. Adequate measures will be taken to provide ingress and egress so designed as to minimize traffic congestion in the public streets.

Response: We will cause no traffic congestion.

6. **No Destruction of Significant Features.** The proposed use and development will not result in the destruction, loss, or damage of any natural, scenic, or historic feature of significant importance.

Response: We will cause no destruction of significant features.

7. **Compliance with Standards.** The special use shall, in all other respects, conform to the applicable regulations of the district in which it is located, except as such regulations may, in each instance, be modified by the Common Council pursuant to the recommendations of the Plan Commission. The proposed use and development shall comply with all additional standards imposed on it by the particular provision of this Division and Ordinance authorizing such use.

Response: We will be in compliance with all standards.

- B. **Special Standards for Specified Special Uses.** When the zoning district regulations authorize a special use in a particular zoning district and that special use is indicated as having special standards, as set forth in Section 15-3.0702 and 15-3.0703 of this Division, a Special Use Permit for such use in such zoning district shall not be recommended or granted unless the applicant shall establish compliance with all such special standards.

Response: We will be in compliance with all special standards.

- C. **Considerations.** In determining whether the applicant's evidence establishes that the foregoing standards have been met, the Plan Commission and the Common Council shall consider the following:

1. **Public Benefit.** Whether and to what extent the proposed use and development at the particular location requested is necessary or desirable to provide a service or a facility that is in the interest of the public convenience or that will contribute to the general welfare of the neighborhood or community.

Response: We will service Franklin and all surrounding communities.

2. **Alternative Locations.** Whether and to what extent such public goals can be met by the location of the proposed use and development at some other site or in some other area that may be more appropriate than the proposed site.

Response: This location and space will take care of our needs for a long time.

3. **Mitigation of Adverse Impacts.** Whether and to what extent all steps possible have been taken to minimize any adverse effects of the proposed use and development on the immediate vicinity through building design, site design, landscaping, and screening.

Response: NA.

4. **Establishment of Precedent of Incompatible Uses in the Surrounding Area.** Whether the use will establish a precedent of, or encourage, more intensive or incompatible uses in the surrounding area.

Response: We will be a great business with high standards to serve the Franklin and surrounding communities.

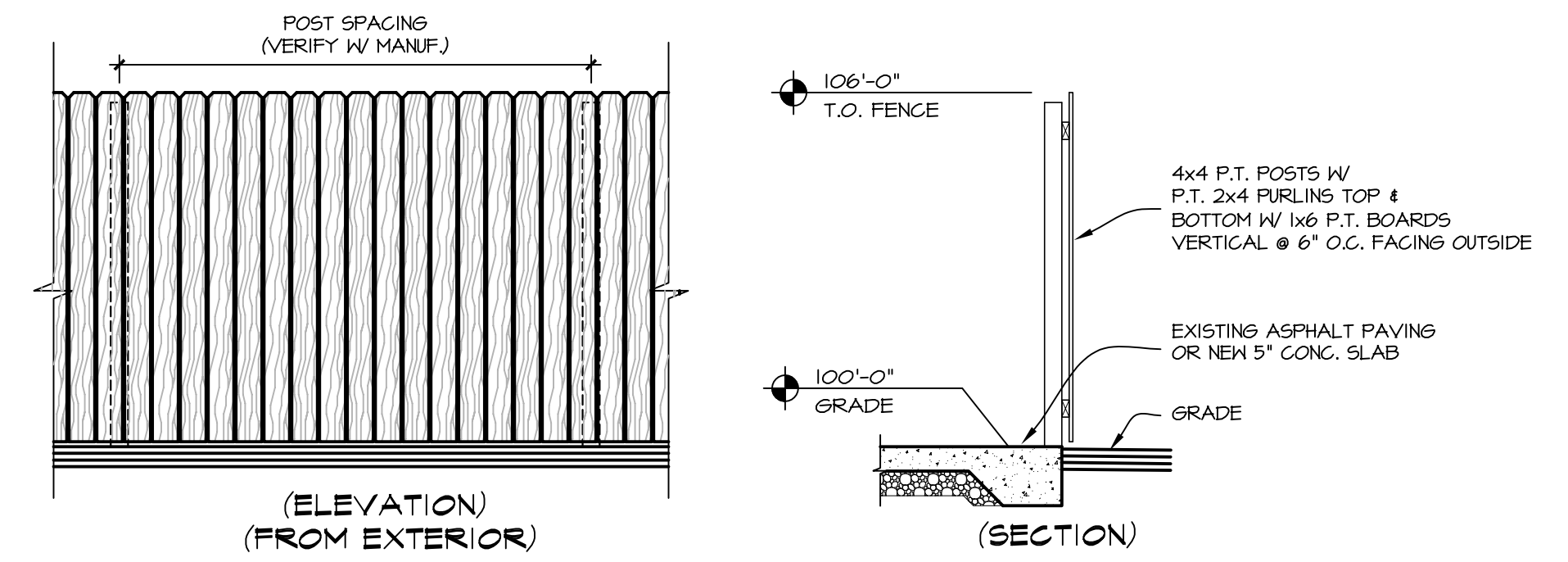

1 TRASH ENCLOSURE FENCE DETAILS
3/8" = 1'-0"

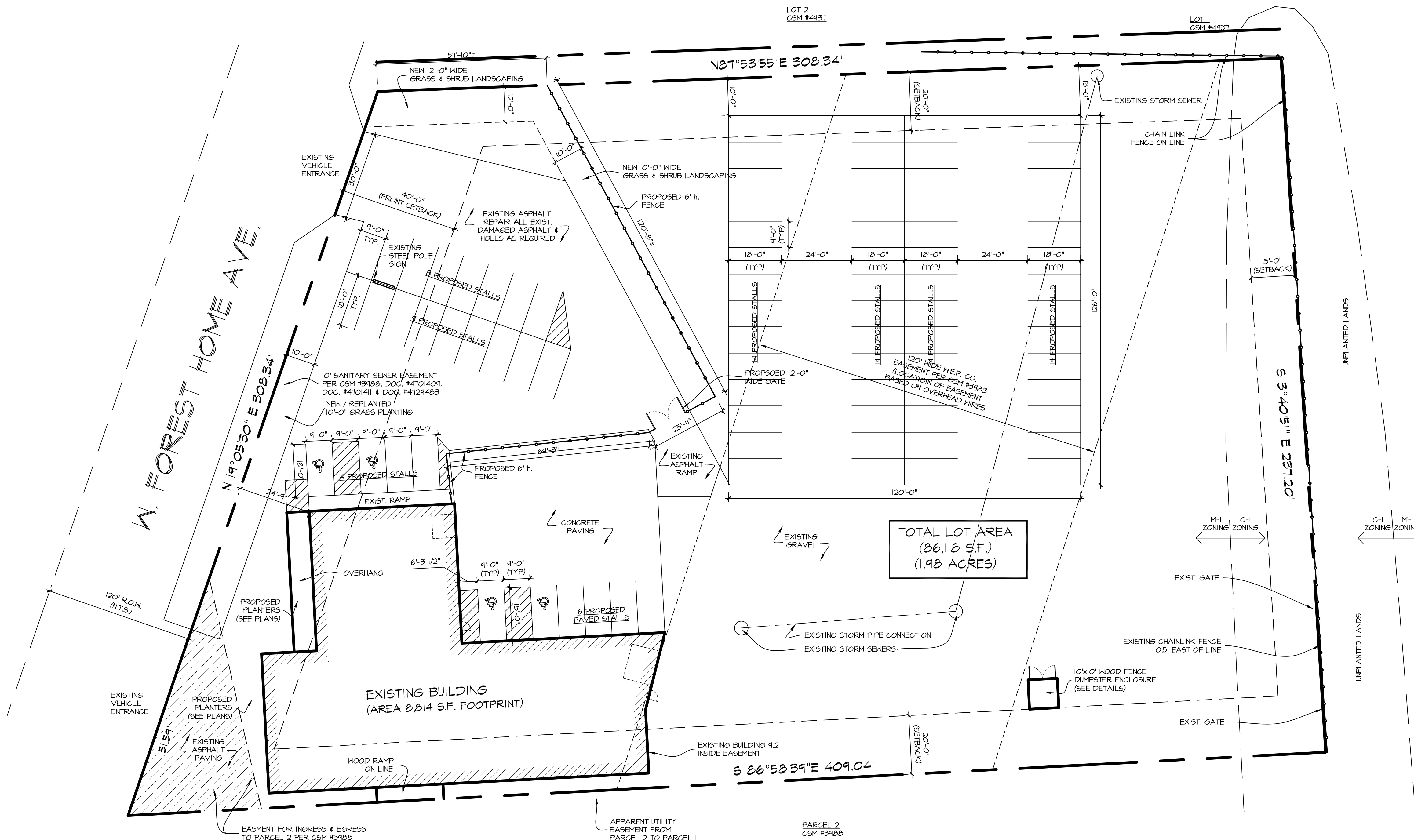

PREVIOUSLY APPROVED DATA: 2/6/15

SITE DATA:

ZONING:	M-1, C-1
LOT AREA:	86,118 S.F.
EXISTING 1ST FLOOR - GENERAL OFFICE:	7,308 S.F.
PROPOSED LOWER LEVEL FLOOR - GENERAL OFFICE:	2,821 S.F.
- CONTRACTORS SHOP:	5,725 S.F.
REQUIRED PARKING:	GENERAL OFFICES (10,129 S.F.) = 33.4 (3.3 PER 1000 S.F.) CONTRACTORS SHOP (5725 S.F.) = 5.7 PLUS 5 (1 PER 1000 S.F. PLUS 1 PER COMPANY CAR)
PROPOSED PARKING:	30 PARKING STALLS (INCL. 2 ADA STALLS)

BUILDING INFO

PROJECT: OGDEN CONSTRUCTION GROUP
 OWNER: 11113 W. FOREST HOME AVENUE, LLC
 ADDRESS: 11113 W. FOREST HOME AVENUE, FRANKLIN, WI 53132
 BUILDING HEIGHT: 16'-0"

SITE DATA:

ZONING:	M-1, C-1
LOT AREA:	86,118 S.F.
EXISTING 1ST FLOOR - GENERAL OFFICE:	7,308 S.F.
- SALONS:	3,782 S.F.
- CONTRACTORS SHOP:	3,526 S.F.
PROPOSED LOWER LEVEL FLOOR - GENERAL OFFICE:	8,546 S.F.
- CONTRACTORS SHOP:	2,821 S.F.
- SALON:	5,725 S.F.
REQUIRED PARKING:	45 PARKING STALLS GENERAL OFFICES (6,603 S.F.) = 21.8 (3.3 PER 1000 S.F.) CONTRACTORS SHOP (5725 S.F.) = 5.7 PLUS 5 (1 PER 1000 S.F. PLUS 1 PER COMPANY CAR) SALON (3 CHAIRS + 3 EMPLOYEES = 12 (3 PER CHAIR PLUS 1 PER EMPLOYEE))
PROPOSED PARKING:	83 PARKING STALLS (INCL. 4 ADA STALLS)
ALLOWED MAX. IMPERVIOUS SURFACE AREA:	51,671 S.F. (60%)
ALLOWED MIN. GREEN SPACE AREA:	34,447 S.F. (40%)
ACTUAL TOTAL IMPERVIOUS SURFACE AREA:	44,200 S.F. (51%)
ACTUAL TOTAL GREEN SPACE AREA:	41,918 S.F. (49%)

SITE DEVELOPMENT PLAN
1" = 20'-0"

OGDEN CONSTRUCTION REMODEL

C-1

DATE: DEC. 1, 2014
PROJECT NUMBER: 14-005

REVISIONS:
 12/1/14: PRELIM #1
 12/23/14: CD'S ISSUED
 1/26/15: UPDATED CD'S
 2/6/15: UPDATED CD'S
 3/25/15: TENANT LAYOUT
 10/4/17: PARKING LOT
 11/29/17: UPDATED PARKING

COPYRIGHT: PATERA LLC...IT IS UNLAWFUL FOR ANYONE TO USE OR REPRODUCE BY ANY MEANS ALL OR ANY PORTION OF THESE CONSTRUCTION DOCUMENTS WITHOUT THE EXPRESSED WRITTEN PERMISSION OF PATERA LLC.

**CITY OF FRANKLIN****REPORT TO THE PLAN COMMISSION****Meeting of January 4, 2018****Special Use**

RECOMMENDATION: City Development Staff recommends approval of the proposed Special Use for an eyelash extension service business use and associated site changes upon property located at 11113 W. Forest Home Avenue, subject to the conditions of approval in the attached draft resolution.

Project Name: Fabu Eyes Special Use

Project Address: 11113 West Forest Home Avenue, Suite 200

Applicant: Fabu, LLC

Owners (property): 11113 West Forest Home Avenue, LLC

Current Zoning: M-1 Limited Industrial District & C-1 Conservancy District

2025 Comprehensive Master Plan Industrial

Use of Surrounding Properties: WE Energies substation and Ewald automobile dealership to the north, gasoline service station to the south, Ewald Truck Center and Hiller Ford automobile dealership to the east and single-family residential to the west.

Applicant Action Requested: Recommendation of approval for the proposed Special Use for Fabu Eyes to operate at 11113 West Forest Home Avenue, Suite 240.

INTRODUCTION:

On October 5, 2017, Joel Cook of Ogden Construction submitted a Special Use application on behalf of Fabu LLC dba Fabu Eyes, requesting approval to operate an eyelash extension service business use within the Falcon Commons building located at 11113 West Forest Home Avenue. The proposed use corresponds to Standard Industrial Classification (SIC) Title No. 7231 Beauty Shops, which is allowed within the M-1 Limited Industrial District as a Special Use.

At the November 9, 2017 Plan Commission meeting, following a properly noticed public hearing, the following action was approved: move to postpone and continue the Public hearing to the December 7, 2017 Plan Commission meeting. It can be noted that the property owner had still been working on a revised set of plans and associated information in response to staff's initial review comments, and had not submitted any materials for the Plan Commission meeting.

At the December 7, 2017 Plan Commission meeting, the public hearing was held, no one spoke on the matter, and the hearing was closed. Although included within the Plan Commission packets, as Ogden Construction did not submit revised plans until November 30th, staff did not have sufficient time to conduct a thorough review. The Plan Commission subsequently moved to "table [this matter] to the January 4, 2018 Plan Commission meeting."

HISTORY:

Fabu Eyes has been operating at 11113 West Forest Home Avenue, Suite 240, since the summer of 2017 without any approvals from the City of Franklin. In order to address this situation, staff has been working with Fabu LLC on obtaining Special Use approval.

This Special Use application also includes a request by the property owner to keep site improvements made without City approvals. Specifically, the parking lot in the northwest corner of the property was reconfigured and a new 15,120 square foot paved parking area was added in the rear of the property.

The applicant's responses to the Special Use Standards and Regulations form are attached.

In addition, some of the terms and conditions from the prior Special Use approval for the subject property (for Ogden Construction Group LLC as set forth in Ordinance 2015-7065), have yet to be addressed, as noted later in this staff report.

PROJECT DESCRIPTION AND ANALYSIS:

The applicant has indicated that they currently occupy the building, have no employees (although the parking analysis assumes three employees), and have made no building or site changes. However, staff has the following concerns as noted below.

Site Plan:

Comparison of the attached Site Development Plan to the previously approved plan in 2015 (as well as a comparison of historic aerial photographs with recent site visits) indicates that the property owner has, without City approvals: reconfigured the parking lot at the northwest corner of the property; added an approximately 15,000 square foot paved parking area in the central portion of the property within the WEPCO easement; and paved the previously graveled area immediately behind (east of) the existing building. While staff has no objection to the changes to the parking lot at the northwest corner of the property and to the parking area immediately behind the building, staff has numerous concerns about the large paved parking area within the WEPCO easement. This will be discussed in detail in the Parking and Stormwater sections of this report.

In a related matter, it must be noted that a number of site plan related conditions of the City's Special Use approval for Ogden Construction in 2015 (Ordinance 2015-7065) have still not been met. These include:

- Condition #1: Pursuant to the approved plans, a 6' wooden fence was proposed along the east and south sides of the northwestern parking lot.
 - Instead, the property owner installed a chain link fence with slats. Pursuant to the approved plans and Section 15-3.0803F. of the UDO (as this screens an open storage area from public view from W. Forest Home Avenue), staff recommends that the property owner shall replace the existing chain link fence along the east and south sides of the northwestern parking lot with a 6' high solid wood fence,

for Department of City Development approval, within 90 days of this approval, or prior to the issuance of any Occupancy Permit, whichever may occur first.

- Condition #4: “An architectural elevation of the 10’ x 10’ wood fence dumpster enclosure shall be submitted to the Department of City Development for review and approval by Staff, prior to issuance of a Building Permit.”
 - While an elevation was provided, the wooden dumpster enclosure was not constructed. In addition, Section 15-3.0803I. of the UDO requires dumpster enclosures to consist of sight proof fencing (wood or masonry) and landscaping, unless waived by the Plan Commission. As this area is area is partially visible from adjacent properties and an enclosure was required of the prior Special Use approval, staff recommends that the property owner shall install a 10’ high sight proof wooden dumpster enclosure, for Department of City Development approval, within 90 days of this approval, or prior to issuance of any Occupancy Permit, whichever may occur first.

It can also be noted that the dumpsters are currently located within the WEPCO easement, and as a condition of approval for location of the paved parking lot within this easement, the American Transmission Company (ATC) has requested that no structures or dumpsters be located within the easement. Therefore, staff recommends that the property owner shall relocate the dumpsters immediately to the east of the WEPCO easement near the southern boundary of the subject property, for Department of City Development approval, within 90 days of this approval, or prior to issuance of any Occupancy Permit, whichever may occur first.

A trailer, apparently over 8,000 lbs, is parked at the rear of the property and is used for storage. As this requires prior City approval pursuant to Section 15-5.0202G.3. of the UDO, and as this was not included within the property owner’s application materials nor indicated within the public hearing notice, staff recommends that the property owner shall remove the trailer and any other commercial vehicles over 8,000 lbs, for Department of City Development approval, within 90 days of this approval, or prior to issuance of any Occupancy Permit, whichever may occur first.

Stormwater Management:

It must be noted that a stormwater related condition of the City’s Special Use approval for Ogden Construction in 2015 (Ordinance 2015-7065) has still not been met.

- Condition #8: “Applicant shall have the stormwater drainage pipe televised to assess its current condition, provide the results of the inspection to the Engineering Department together with a location map, repair the pipe as may be necessary, and grant the City of Franklin an easement to protect and access the pipe.”
 - In response, the property owner has only identified the location of the manholes associated with the storm sewer, and has drawn a straight line between those two points. As this condition has still not been addressed, staff recommends that the property owner shall have the stormwater drainage pipe televised to assess its current condition, provide the results of the inspection to the Engineering Department together with a location map, repair the pipe as may be necessary,

and grant the City of Franklin an easement to protect and access the pipe, prior to June 1, 2018.

As previously noted, the property owner has constructed a paved parking area without City approvals. Although the owner states that this was located within a previously graveled area, staff partially disagrees, based upon review of historic aerial photographs and current site conditions. Staff also disagrees with the property owner's calculations of pervious and impervious areas. Therefore, staff recommends that the property owner shall prepare a stormwater management plan pursuant to Section 15-7.0103 of the UDO, for Engineering Department review and approval, within 90 days of this approval, or prior to issuance of any Occupancy Permit, whichever may occur first.

Although the subject parking lot has already been constructed, grading, filling, and/or other land disturbing activities has occurred which could impact site drainage. In addition, as noted in the parking section of this report, additional land disturbing activities are recommended by staff. As such, staff recommends that the property owner shall prepare a Grading/Drainage/Erosion Control Plan for Engineering Department review and approval, within 90 days of this approval, or prior to issuance of any Occupancy Permit, whichever may occur first.

Parking:

Pursuant to the current uses within the subject building, and the parking standards contained within the UDO, 45 parking spaces are required. However, the subject property provides 83 parking spaces, or 38 spaces or about 84 percent more than required. While Section 15-5.0203 of the UDO allows parking increases above 10% of the standard parking ratio, with the submittal of reasonably sufficient proof that additional parking is needed, staff does not believe that sufficient information has been submitted. Although Fabu Eyes did not indicate that they utilize the rear parking area, the site as a whole has excessive parking. Therefore, staff recommends that the property owner shall remove approximately 20 parking spaces, and restore the area to turf lawn, for Department of City Development review and approval, prior to June 1, 2018. Staff would note that removal of such parking, and restoration to a grassy surface, might benefit the stormwater management plan from the standpoint of the amount of impervious surface and the sizing of any required stormwater facilities.

Pursuant to Section 15-5.0202E. of the UDO, staff recommends that the property owner shall install curb and gutter for the recently paved parking area, for Engineering Department review and approval, prior to June 1, 2018. It can be noted that the UDO does allow the Plan Commission to waive this requirement for additions to existing structures located in areas without a predominance of curb and gutter. Although Fabu Eyes did not indicate that they utilize the rear parking area, the parking is available to the site as a whole. Therefore, as this parking area is not due to a building addition, is separate from the existing paved parking areas, and such installation could potentially benefit site drainage/stormwater efforts, staff would continue to recommend that curb and gutter be installed at this time.

Landscaping:

Although the property owner has paved an additional parking area, the owner has not prepared a revised landscape plan, nor verified the minimum required Landscape Surface Ratio pursuant to that plan, nor installed any additional plantings for the additional parking spaces. Therefore,

staff recommends that the property owner shall prepare a Landscape Plan pursuant to Divisions 15-5.0300 and 15-7.0300 of the UDO, for review and approval by the Department of City Development, within 90 days of this approval, or prior to issuance of any Occupancy Permit, whichever may occur first. Staff further recommends that the property owner shall install all required landscaping prior to June 1, 2018.

Natural Resource Protection Plan:

It can be noted that C-1 Conservancy District zoning is located on the far eastern portion of the subject property, and that a Natural Resource Protection Plan has not been prepared for the subject property. However, the City does have on file a letter from R.A. Smith National Inc. dated 2011 that indicates there are no protected natural resource features within the subject property. Although site changes were not proposed within the eastern half of the property in the 2015 Special Use request, the property owner has since constructed a paved parking area approximately 50' from the C-1 zoning district. Therefore, *staff suggests that the property owner prepare a Natural Resource Protection Plan for Department of City Development review and approval. Furthermore, staff suggests that the property owner apply for a rezoning to remove the C-1 zoning district from the subject property.*

Signage:

The applicant and the property owner have indicated that no new signage is proposed, and have been advised that any signage will require separate review and approval by the Architectural Review Board and issuance of a Sign Permit from the Inspection Department.

STAFF RECOMMENDATION:

Due to the fact that the property owner has not completed all of the conditions associated with the 2015 Special Use approval, as the property owner had constructed a parking lot without City approvals, as a number of related conditions are proposed in the current Special Use request, and pursuant to Sections 15-3.0701D. and E. of the UDO (regarding Conditions on Special Use Permits), and Section 15-7.0105 of the UDO (regarding Site Plan improvements), staff recommends that the property owner shall provide an appropriate financial surety to guarantee that improvements including improved off-street parking, open space areas, utilities, and landscaping will be completed on schedule, for Department of City Development and Engineering Department review and approval within 60 days of this approval or prior to issuance of any Occupancy Permit whichever may occur first. It can be noted that staff envisions that the one financial surety would be submitted, which would address both the Fabu Eyes as well as the Molly Maids Special Use requests.

City Development Staff recommends approval of the proposed Special Use for an eyelash extension service business use and associated site changes upon property located at 11113 W. Forest Home Avenue, subject to the conditions of approval in the attached draft resolution.

RESOLUTION NO. 2017-_____

A RESOLUTION IMPOSING CONDITIONS AND RESTRICTIONS
FOR THE APPROVAL OF A SPECIAL USE FOR AN EYELASH
EXTENSION SERVICE BUSINESS USE UPON PROPERTY LOCATED
AT 11113 WEST FOREST HOME AVENUE, SUITE 240
(YULIA DA SILVA, OWNER, FABU LLC, D/B/A FABÚ EYES, APPLICANT)

WHEREAS, Yulia Da Silva, owner, Fabu LLC, d/b/a Fabù Eyes, having petitioned the City of Franklin for the approval of a Special Use within an M-1 Limited Industrial District and C-1 Conservancy District under Standard Industrial Classification Title No. 7231 “Beauty Shops”, to allow for an eyelash extension service business use, with hours of operation from 9:00 a.m. to 7:00 p.m., Monday through Friday, and 9:00 a.m. to 2:00 p.m., Saturday and Sunday, upon property located at 11113 West Forest Home Avenue, Suite 240, bearing Tax Key No. 704-9978-002, more particularly described as follows:

Parcel 1 of Certified Survey Map No. 3988, recorded on March 11, 1981, Reel 1362, Images 185 to 187, as Document No. 5462366, being a part of the Northeast 1/4 of Section 6, Town 5 North, Range 21 East, in the City of Franklin, County of Milwaukee, State of Wisconsin; and

WHEREAS, such petition having been duly referred to the Plan Commission of the City of Franklin for a public hearing, pursuant to the requirements of §15-9.0103D. of the Unified Development Ordinance, and a public hearing having been held before the Plan Commission on the 9th day of November, 2017, and continued on the 7th day of December 2017, and the Plan Commission thereafter having determined to recommend that the proposed Special Use be approved, subject to certain conditions, and the Plan Commission further finding that the proposed Special Use upon such conditions, pursuant to §15-3.0701 of the Unified Development Ordinance, will be in harmony with the purposes of the Unified Development Ordinance and the Comprehensive Master Plan; that it will not have an undue adverse impact upon adjoining property; that it will not interfere with the development of neighboring property; that it will be served adequately by essential public facilities and services; that it will not cause undue traffic congestion; and that it will not result in damage to property of significant importance to nature, history or the like; and

WHEREAS, the Common Council having received such Plan Commission recommendation and also having found that the proposed Special Use, subject to conditions, meets the standards set forth under §15-3.0701 of the Unified Development Ordinance.

NOW, THEREFORE, BE IT RESOLVED, by the Mayor and Common Council of the City of Franklin, Wisconsin, that the petition of Yulia Da Silva, owner, Fabu LLC, d/b/a Fabù Eyes, for the approval of a Special Use for the property particularly described in the

YULIA DA SILVA, OWNER, FABU LLC, D/B/A FABÚ EYES – SPECIAL USE
RESOLUTION NO. 2017-_____

Page 2

preamble to this Resolution, be and the same is hereby approved, subject to the following conditions and restrictions:

1. That this Special Use is approved only for the use of the subject property by Yulia Da Silva, owner, Fabu LLC, d/b/a Fabù Eyes, successors and assigns, as an eyelash extension service business use, which shall be developed in substantial compliance with, and operated and maintained by Yulia Da Silva, owner, Fabu LLC, d/b/a Fabù Eyes, pursuant to those plans City file-stamped November 30, 2017 and annexed hereto and incorporated herein as Exhibit A.
2. Yulia Da Silva, owner, Fabu LLC, d/b/a Fabù Eyes, successors and assigns, shall pay to the City of Franklin the amount of all development compliance, inspection and review fees incurred by the City of Franklin, including fees of consults to the City of Franklin, for the Yulia Da Silva, owner, Fabu LLC, d/b/a Fabù Eyes eyelash extension service business, within 30 days of invoice for same. Any violation of this provision shall be a violation of the Unified Development Ordinance, and subject to §15-9.0502 thereof and §1-19. of the Municipal Code, the general penalties and remedies provisions, as amended from time to time.
3. The approval granted hereunder is conditional upon Yulia Da Silva, owner, Fabu LLC, d/b/a Fabù Eyes and the eyelash extension service business use for the property located at 11113 West Forest Home Avenue, Suite 240: (i) being in compliance with all applicable governmental laws, statutes, rules, codes, orders and ordinances; and (ii) obtaining all other governmental approvals, permits, licenses and the like, required for and applicable to the project to be developed and as presented for this approval.
4. The property owner shall replace the existing chain link fence along the east and south sides of the northwestern parking lot with a 6' high solid wood fence, for Department of City Development approval, within 90 days of this approval or prior to the issuance of any Occupancy Permit whichever may occur first.
5. The property owner shall install a 10' high sight proof wooden dumpster enclosure, for Department of City Development approval, within 90 days of this approval or prior to issuance of any Occupancy Permit whichever may occur first.
6. The property owner shall relocate the dumpsters immediately to the east of the WEPCO easement near the southern boundary of the subject property, for Department of City Development approval, within 90 days of this approval or prior to issuance of any Occupancy Permit whichever may occur first.

7. The property owner shall remove the trailer and any other commercial vehicles over 8,000 lbs, for Department of City Development approval, within 90 days of this approval or prior to issuance of any Occupancy Permit whichever may occur first.
8. The property owner shall have the stormwater drainage pipe televised to assess its current condition, provide the results of the inspection to the Engineering Department together with a location map, repair the pipe as may be necessary, and grant the City of Franklin an easement to protect and access the pipe, prior to June 1, 2018.
9. The property owner shall prepare a stormwater management plan pursuant to Section 15-7.0103 of the UDO, for Engineering Department review and approval, within 90 days of this approval or prior to issuance of any Occupancy Permit whichever may occur first.
10. The property owner shall prepare a Grading/Drainage/Erosion Control Plan for Engineering Department review and approval, within 90 days of this approval or prior to issuance of any Occupancy Permit whichever may occur first.
11. The property owner shall remove approximately 20 parking spaces, and restore the area to turf lawn, for Department of City Development review and approval, prior to June 1, 2018.
12. The property owner shall install curb and gutter for the recently paved parking area, for Engineering Department review and approval, prior to June 1, 2018.
13. The property owner shall prepare a Landscape Plan pursuant to Divisions 15-5.0300 and 15-7.0300 of the UDO, for review and approval by the Department of City Development, within 90 days of this approval or prior to issuance of any Occupancy Permit whichever may occur first.
14. The property owner shall install all required landscaping prior to June 1, 2018.
15. The property owner shall provide an appropriate financial surety to guarantee that improvements including improved off-street parking, open space areas, utilities, and landscaping will be completed on schedule, for Department of City Development and Engineering Department review and approval within 60 days of this approval or prior to issuance of any Occupancy Permit whichever may occur first
16. [other conditions, etc.]

R & R SWAN INVESTMENTS, LLC, /D/B/A MOLLY MAID – SPECIAL USE
RESOLUTION NO. 2017-_____

Page 4

BE IT FURTHER RESOLVED, that in the event Yulia Da Silva, owner, Fabu LLC, d/b/a Fabù Eyes, successors or assigns, or any owner of the subject property, does not comply with one or any of the conditions and restrictions of this Special Use Resolution, following a ten (10) day notice to cure, and failure to comply within such time period, the Common Council, upon notice and hearing, may revoke the Special Use permission granted under this Resolution.

BE IT FURTHER RESOLVED, that any violation of any term, condition or restriction of this Resolution is hereby deemed to be, and therefore shall be, a violation of the Unified Development Ordinance, and pursuant to §15-9.0502 thereof and §1-19. of the Municipal Code, the penalty for such violation shall be a forfeiture of no more than \$2,500.00, or such other maximum amount and together with such other costs and terms as may be specified therein from time to time. Each day that such violation continues shall be a separate violation. Failure of the City to enforce any such violation shall not be a waiver of that or any other violation.

BE IT FURTHER RESOLVED, that this Resolution shall be construed to be such Special Use Permit as is contemplated by §15-9.0103 of the Unified Development Ordinance.

BE IT FURTHER RESOLVED, pursuant to §15-9.0103G. of the Unified Development Ordinance, that the Special Use permission granted under this Resolution shall be null and void upon the expiration of one year from the date of adoption of this Resolution, unless the Special Use has been established by way of the issuance of an occupancy permit for such use.

BE IT FINALLY RESOLVED, that the City Clerk be and is hereby directed to obtain the recording of a certified copy of this Resolution in the Office of the Register of Deeds for Milwaukee County, Wisconsin.

Introduced at a regular meeting of the Common Council of the City of Franklin this _____ day of _____, 2017.

Passed and adopted at a regular meeting of the Common Council of the City of Franklin this _____ day of _____, 2017.

YULIA DA SILVA, OWNER, FABU LLC, D/B/A FABÚ EYES – SPECIAL USE
RESOLUTION NO. 2017-_____

Page 5

APPROVED:

Stephen R. Olson, Mayor

ATTEST:

Sandra L. Wesolowski, City Clerk

AYES _____ NOES _____ ABSENT _____

11113 W. Forest Home Ave.
TKN: 704 9978 002



Planning Department
(414) 425-4024

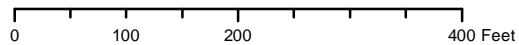

This map shows the approximate relative location of property boundaries but was not prepared by a professional land surveyor. This map is provided for informational purposes only and may not be sufficient or appropriate for legal, engineering, or surveying purposes.

11113 W. Forest Home Ave.
TKN: 704 9978 002

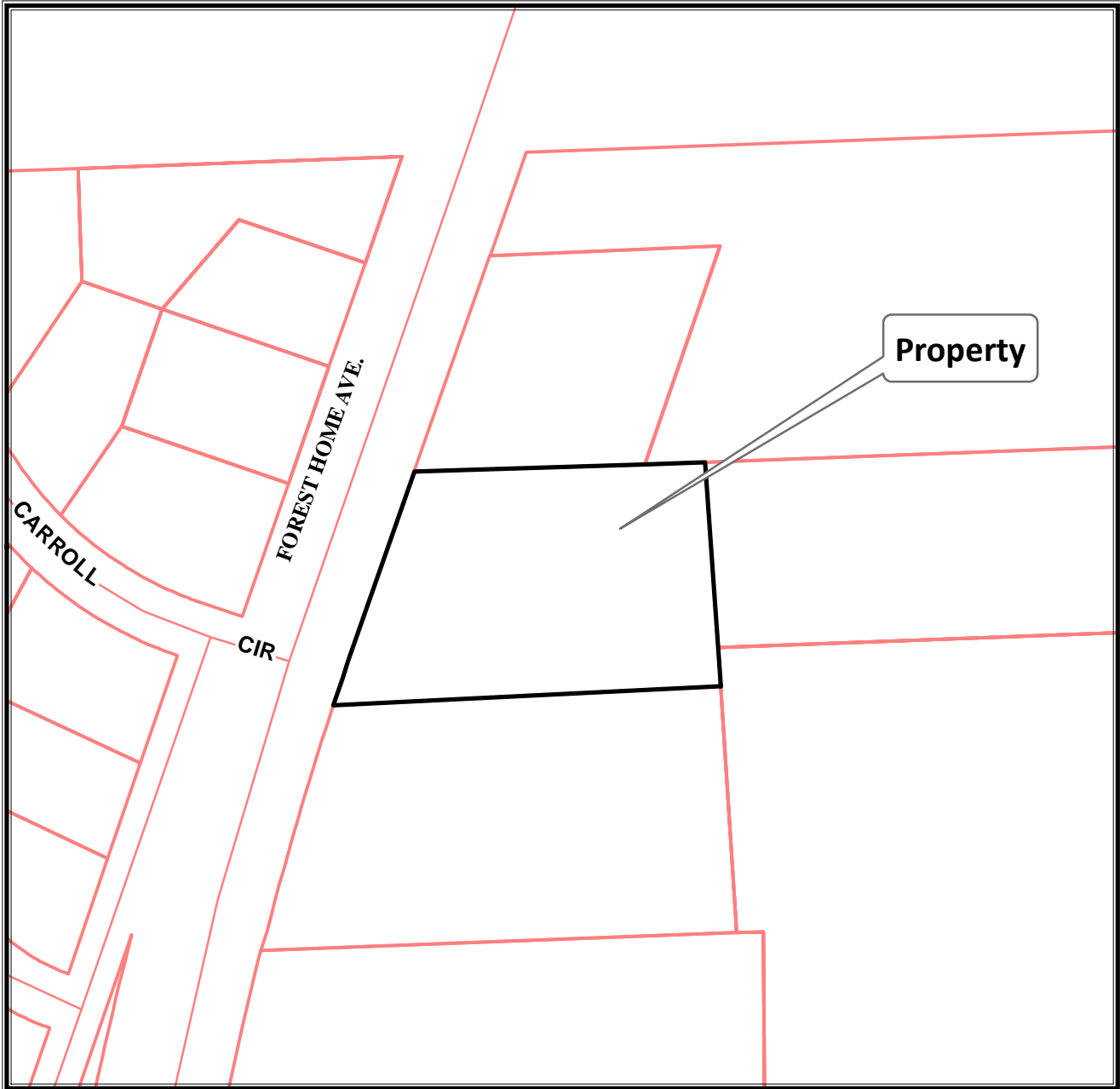

Planning Department
(414) 425-4024

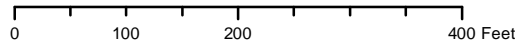

This map shows the approximate relative location of property boundaries but was not prepared by a professional land surveyor. This map is provided for informational purposes only and may not be sufficient or appropriate for legal, engineering, or surveying purposes.



Fabu Eyes

To whom it may concern,

Fabu LLC, DBA Fabu Eyes operates a professional eyelash extensions service. We operate 7 days a week; Monday through Friday from 9am to 7pm, Saturday and Sunday from 9am to 2pm. There are no employees. The current location is 11113 W Forest Home Ave, Suite 240, Franklin WI, 53132. We took the space as is, no work has been done to our space.

Thank You,



Yulia Da Silva

Fabu LLC

619-852-2521

Franklin

NOV 30 2017

City Development

Fabu Eyes

11113 W Forest Home Ave, Suite 240, Franklin WI 53132

Tel: 414-367-2379

www.fabueyes.com

November 28, 2017

Orrin Sumwalt
City Plan Commission
City of Franklin
9229 W Loomis Rd
Franklin, WI 53132

RE: Fabu Eyes

I am writing in response to your staff comments dated 10/19/17.

Site Plan (UDO)

- 1.) owners name & address are on the attached site plan
- 2.) right of way widths are on the attached site plan
- 3.) storm sewer is now shown on the attached site plan
- 4.) storm water management is not required per attached over heads
- 5.) see attached landscape plan previously submitted & approved
- 6.) no new lighting was installed nor proposed
- 7.) see attached site plan showing that the parking lot is not in the C-1 zoning

Site Plan (staff)

- 1.) see attached site plan
- 2.) the (2) dumpsters are screened by the vision slatted fence at the upper parking lot & is not visible from the road- would that be acceptable?
- 3.) Ogden Construction installed 6'-0" high chain link fence with vision slats
- 4.) the site data or attached site plan verifies the surface ratio
- 5.) see attached site plan

- 6.) we feel that because the parking is depressed the landscaping will only be seen by us and will not be seen by any of the neighbors, therefore, we request that the landscape request be waived

- 7.) see #6

Franklin
NOV 30 2017

City Development

8.) see #6

Parking

- 8.) 10' set back was held see attached site plan
- 9.) Per 15-5.0203B of UDO Forest Home Ave does not have curb and gutter, therefore, they are not required
- 10.) The maximum # of parking is not enough due to the fact that Molly Maids has 2-3 people per car. This means 2-3 people have their personal cars as well as the company owned cars will be present for a period in the morning and evening which requires a higher parking load at those times only.

Sign Plan

- 11.) No signage is proposed

Project Summary

- 12.) There were no improvements to the existing building when Molly Maids moved in, however, we did pave an area on the lower tier to accommodate parking in June of 2017.
- 13.) We acquired a semi-trailer from an associate that had no further use for it and we are using it for storage. If this is an issue we will have it removed. No other commercial vehicles weighing over 8000lbs are on the site.
- 14.) Site improvements (paving) cost \$17,942.00

Other

- 15.) Approval from ATC is pending
- 16.) All outdoor storage/vehicles currently in the C-1 area will be removed

Engineering Dept Comments

- 17.) No grading was completed or is anticipated
- 18.) See attached aerials
- 19.) ATC has been informed; see #15
- 20.) Typo has been corrected

If you have any questions, please do not hesitate to call us.

Sincerely,

Ogden Construction Group, LLC

Joel Cook
President

Joel Cook

From: Tony Zanon [tony.zanon@pinnacle-engr.com]
Sent: Tuesday, November 28, 2017 1:36 PM
To: Joel Cook
Subject: Franklin
Attachments: Site plan markup 11-15-17.pdf; 2000 Aerial.pdf

Joel,
Franklin requires storm water management when land disturbance is greater than one acre or the increase in impervious is greater than 0.5 acres. Wisconsin DNR requires storm water management when disturbance is greater than one acre. MMSD is when disturbance is greater than 2 acres or new impervious is greater than 0.5 acres.

In 2000 there was 49,600 +/- SF of impervious. Per the architects site plan the impervious area on site is now 44,200 SF so there is not an increase in impervious area.

See the attached map, I assume you roughly disturbed the area in green when building the parking lot. That area is approximately 24,200 SF (0.56 acres) so there was not land disturbance over one acre. Please confirm the green area is correct.

Storm water management would not be required because you did not increase impervious by 0.5 acres or more and did not disturb over one acre of land.

Tony

Anthony S. Zanon, P.E. | Senior Project Manager



15850 W. Bluemound Road | Suite 210 | Brookfield, WI 53005
(262) 754-8888 Main | (262) 754-0839 Direct | (262) 754-8850 Fax
tony.zanon@pinnacle-engr.com | www.pinnacle-engr.com

PLAN | DESIGN | DELIVER

CONFIDENTIALITY NOTICE:

This message is intended for the use of the individual or entity to which it is addressed and may contain information that is privileged, confidential and/or exempt from disclosure under applicable law. If the reader of this message is not the intended recipient or the employee or agent responsible for delivering this message to the intended recipient, you are hereby notified that any dissemination, distribution or copying of this communication is strictly prohibited. If you have received this communication in error, please notify us immediately by email reply.

Franklin

NOV 30 2017

City Development

MILWAUKEE COUNTY INTERACTIVE MAPPING SERVICE

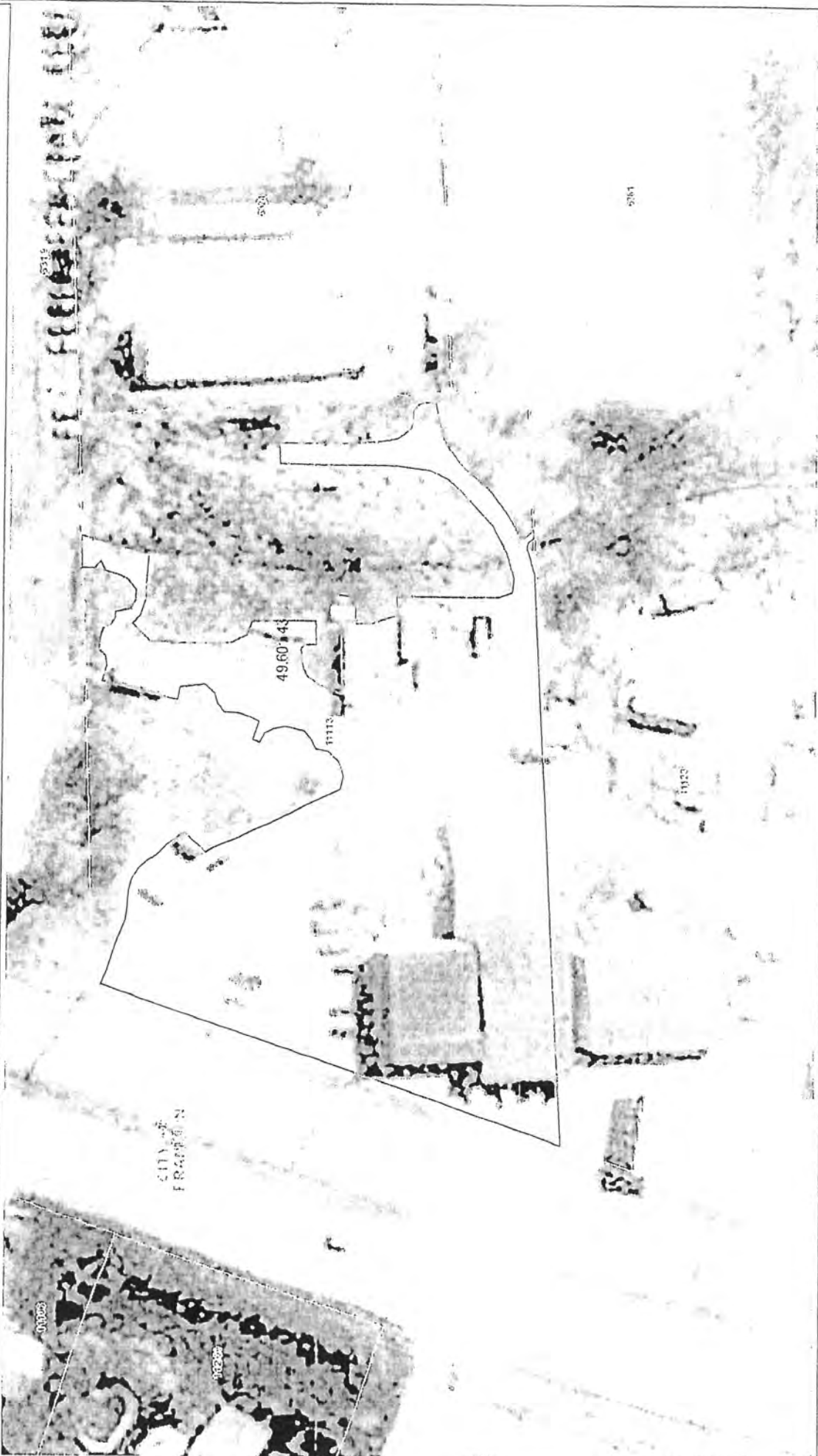

94 0 47 94 Feet 1:564



NAD_1983_StatePlane_Wisconsin_South_FIPS_4803
© MCAMUS

THIS MAP IS NOT TO BE USED FOR NAVIGATION

NOTES

DISCLAIMER: This map is a user generated static output from the Milwaukee County Land Information Office Interactive Mapping Service. While the contents herein are believed to be accurate, the user assumes all responsibility for the accuracy or reliability. No liability is assumed for the Area information herein, either expressed or implied, by Milwaukee County or its employees.

2000 AERIAL

THE ARCHITECT'S RESPONSIBILITY IS TO DESIGN AND CONSTRUCT A BUILDING THAT MEETS THE CLIENT'S REQUIREMENTS AND IS IN ACCORDANCE WITH ALL APPLICABLE CODES AND REGULATIONS. THE ARCHITECT DOES NOT GUARANTEE THE ACCURACY OF THE INFORMATION PROVIDED BY THE CLIENT OR THE RESULTS OF THE DESIGN. THE ARCHITECT'S LIABILITY IS LIMITED TO THE DESIGN AND CONSTRUCTION OF THE BUILDING.

OGDEN CONSTRUCTION REMODEL
 PROPOSED SITE DEVELOPMENT PLAN & DETAILS

SHEET NO. C-1
 DATE: 04-1-2004

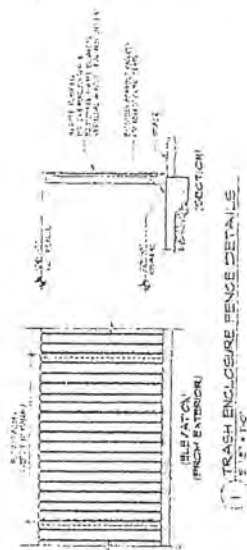

PREVIOUSLY APPROVED DATA: 2/6/15
SITE DATA:
 1. ADDRESS: 12345 MAIN ST, SUITE 100, DALLAS, TX 75201
 2. OWNER: J. SMITH
 3. PROJECT NO.: 15-001
 4. DATE: 02/06/15
 5. SCALE: AS SHOWN
 6. DRAWN BY: J. SMITH
 7. CHECKED BY: J. SMITH

BUILDING INFO:
 1. PROJECT NO.: 15-001
 2. ADDRESS: 12345 MAIN ST, SUITE 100, DALLAS, TX 75201
 3. OWNER: J. SMITH
 4. DATE: 02/06/15
 5. SCALE: AS SHOWN
 6. DRAWN BY: J. SMITH
 7. CHECKED BY: J. SMITH



SITE DEVELOPMENT PLAN

15-001

DIVISION 15-3.0700

SPECIAL USE STANDARDS AND REGULATIONS

SECTION 15-3.0701

GENERAL STANDARDS FOR SPECIAL USES

A. ***General Standards.*** No special use permit shall be recommended or granted pursuant to this Ordinance unless the applicant shall establish the following:

1. **Ordinance and Comprehensive Master Plan Purposes and Intent.** The proposed use and development will be in harmony with the general and specific purposes for which this Ordinance was enacted and for which the regulations of the zoning district in question were established and with the general purpose and intent of the City of Franklin Comprehensive Master Plan or element thereof.

Response: Beauty shop is one of the listed Special Uses and does fit with the intent of the comprehensive master plan

2. **No Undue Adverse Impact.** The proposed use and development will not have a substantial or undue adverse or detrimental effect upon or endanger adjacent property, the character of the area, or the public health, safety, morals, comfort, and general welfare and not substantially diminish and impair property values within the community or neighborhood.

Response: This proposal will in no way adversely affect any other property in area

3. **No Interference with Surrounding Development.** The proposed use and development will be constructed, arranged, and operated so as not to dominate the immediate vicinity or to interfere with the use and development of neighboring property in accordance with the applicable zoning district regulations.

Response: There will be no interference with surrounding developments as the space already existed and we are planning no changes to building

4. **Adequate Public Facilities.** The proposed use and development will be served adequately by essential public facilities and services such as streets, public utilities including public water supply system and sanitary sewer, police and fire protection, refuse disposal, public parks, libraries, schools, and other public facilities and utilities or the applicant will provide adequately for such facilities.

Response: The public facilities are adequate as is; we do not even use public trash collection

5. **No Traffic Congestion.** The proposed use and development will not cause undue traffic congestion nor draw significant amounts of traffic through residential streets. Adequate measures will be taken to provide ingress and egress so designed as to minimize traffic congestion in the public streets.

Response: The proposed tenant will draw 2 - 3 per two hours of operation

6. **No Destruction of Significant Features.** The proposed use and development will not result in the destruction, loss, or damage of any natural, scenic, or historic feature of significant importance.

Response: There will be no destruction of significant features as the space is existing

7. **Compliance with Standards.** The special use shall, in all other respects, conform to the applicable regulations of the district in which it is located, except as such regulations may, in each instance, be modified by the Common Council pursuant to the recommendations of the Plan Commission. The proposed use and development shall comply with all additional standards imposed on it by the particular provision of this Division and Ordinance authorizing such use.

Response: We will comply with all standards. The space is existing and we only plan on painting

- B. **Special Standards for Specified Special Uses.** When the zoning district regulations authorize a special use in a particular zoning district and that special use is indicated as having special standards, as set forth in Section 15-3.0702 and 15-3.0703 of this Division, a Special Use Permit for such use in such zoning district shall not be recommended or granted unless the applicant shall establish compliance with all such special standards.

Response:

- C. **Considerations.** In determining whether the applicant's evidence establishes that the foregoing standards have been met, the Plan Commission and the Common Council shall consider the following:

1. **Public Benefit.** Whether and to what extent the proposed use and development at the particular location requested is necessary or desirable to provide a service or a facility that is in the interest of the public convenience or that will contribute to the general welfare of the neighborhood or community.

Response: The beauty salon will be open to all residents of Franklin and should increase the aesthetic appeal of the residents of Franklin

2. **Alternative Locations.** Whether and to what extent such public goals can be met by the location of the proposed use and development at some other site or in some other area that may be more appropriate than the proposed site.

Response: This business was previously renting in Hales Corners and our location was the only space in the area that fit into their budget

3. **Mitigation of Adverse Impacts.** Whether and to what extent all steps possible have been taken to minimize any adverse effects of the proposed use and development on the immediate vicinity through building design, site design, landscaping, and screening.

Response: There will be no adverse effects as we are not changing anything at all

4. **Establishment of Precedent of Incompatible Uses in the Surrounding Area.** Whether the use will establish a precedent of, or encourage, more intensive or incompatible uses in the surrounding area.

Response: I do not feel this will set a precedent for beauty shops to be allowed in M-1 Zoning because this shop is the only beauty shop of this nature in this area of Franklin and is a needed asset to the community.

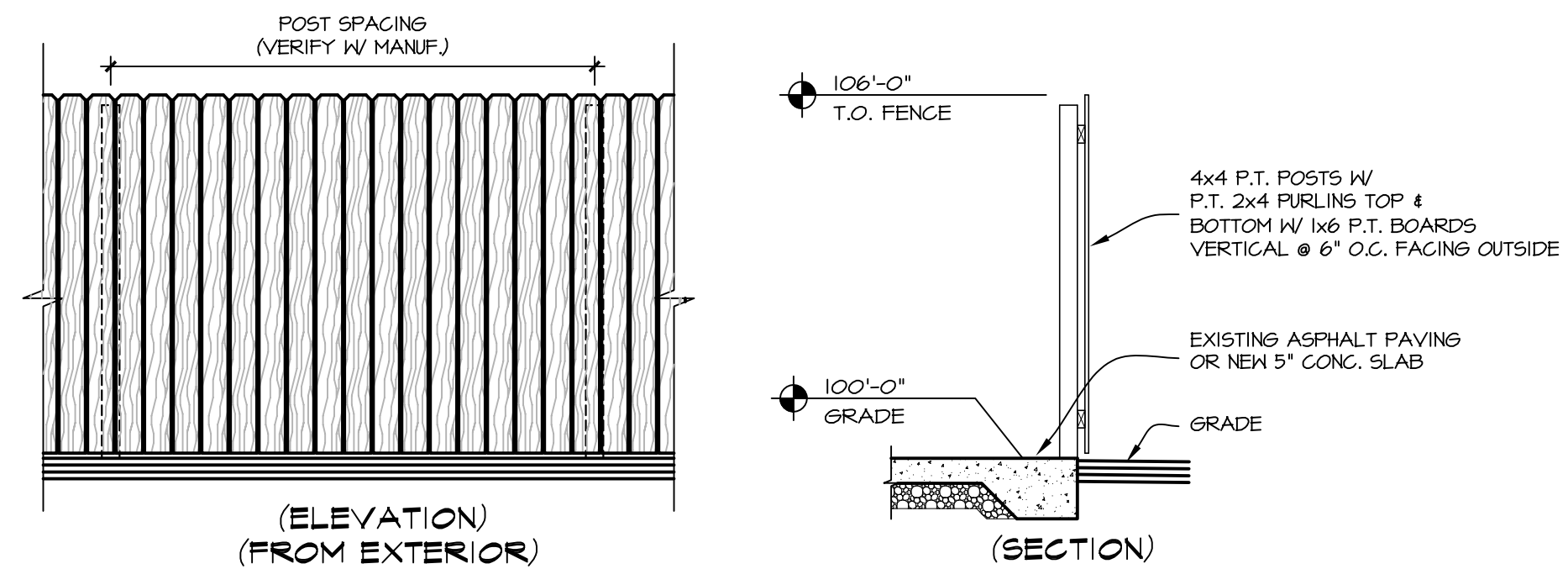

1 TRASH ENCLOSURE FENCE DETAILS
3/8" = 1'-0"

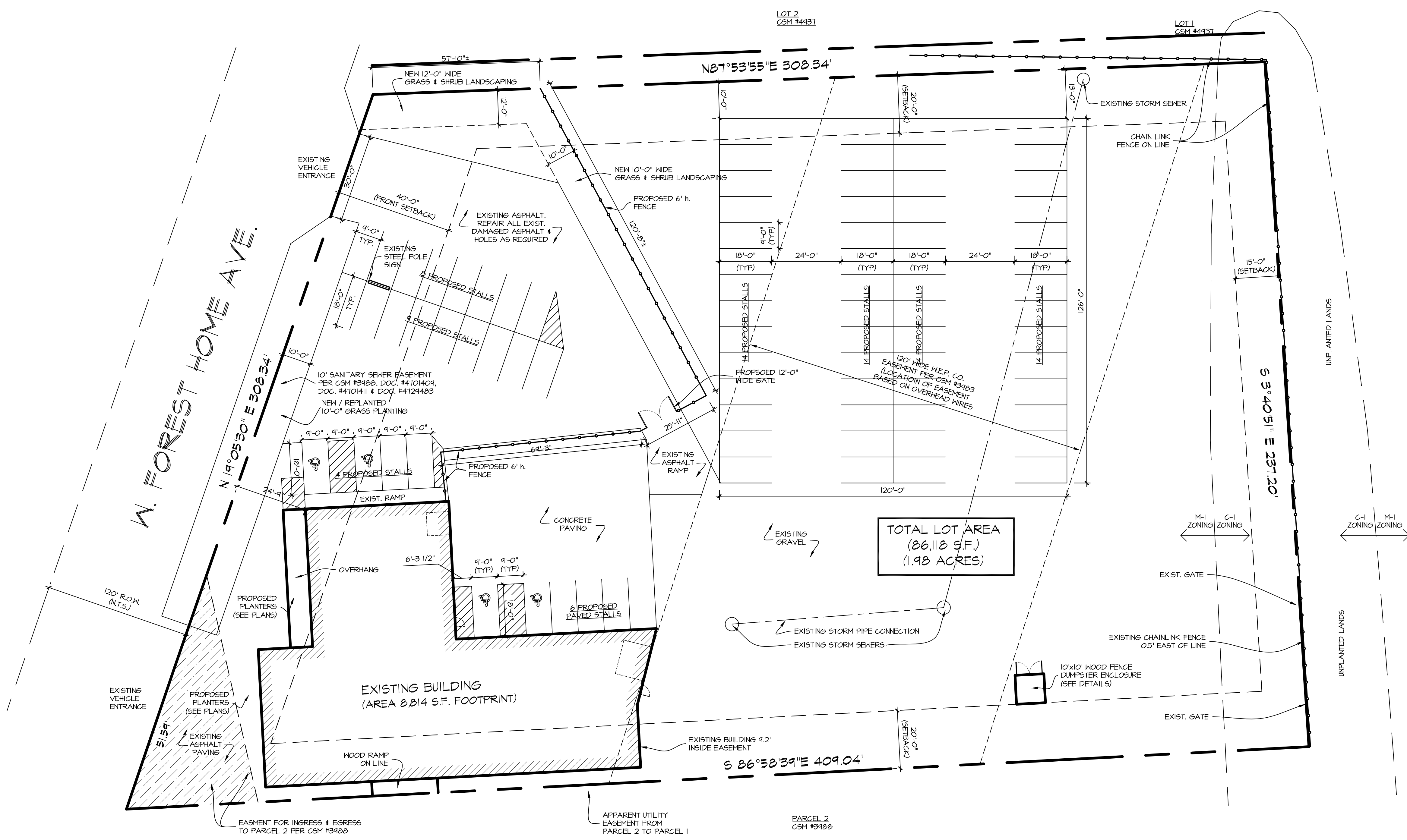

SITE DEVELOPMENT PLAN
1" = 20'-0"

PREVIOUSLY APPROVED DATA: 2/6/15

SITE DATA:	
ZONING:	M-1, C-1
LOT AREA:	86,118 S.F.
EXISTING 1ST FLOOR - GENERAL OFFICE:	7,308 S.F.
PROPOSED LOWER LEVEL FLOOR - GENERAL OFFICE:	2,821 S.F.
- CONTRACTORS SHOP:	5,725 S.F.
REQUIRED PARKING:	GENERAL OFFICES (10,129 S.F.) = 33.4 (3.3 PER 1000 S.F.) CONTRACTORS SHOP (5725 S.F.) = 5.7 PLUS 5 (1 PER 1000 S.F. PLUS 1 PER COMPANY CAR)
PROPOSED PARKING:	30 PARKING STALLS (INCL. 2 ADA STALLS)

BUILDING INFO	
PROJECT:	OGDEN CONSTRUCTION GROUP
OWNER:	11113 W. FOREST HOME AVENUE, LLC
ADDRESS:	11113 W. FOREST HOME AVE. FRANKLIN, WI 53132
BUILDING HEIGHT:	16'-0"

SITE DATA:	
ZONING:	M-1, C-1
LOT AREA:	86,118 S.F.
EXISTING 1ST FLOOR - GENERAL OFFICE:	7,308 S.F.
- SALONS:	3,782 S.F.
- SALONS:	3,526 S.F.
PROPOSED LOWER LEVEL FLOOR - GENERAL OFFICE:	8,546 S.F.
- CONTRACTORS SHOP:	2,821 S.F.
- CONTRACTORS SHOP:	5,725 S.F.
REQUIRED PARKING:	45 PARKING STALLS GENERAL OFFICES (6,603 S.F.) = 21.8 (3.3 PER 1000 S.F.) CONTRACTORS SHOP (5725 S.F.) = 5.7 PLUS 5 (1 PER 1000 S.F. PLUS 1 PER COMPANY CAR) SALON (3 CHAIRS + 3 EMPLOYEES = 12 (3 PER CHAIR PLUS 1 PER EMPLOYEE))
PROPOSED PARKING:	83 PARKING STALLS (INCL. 4 ADA STALLS)
ALLOWED MAX. IMPERVIOUS SURFACE AREA:	51,671 S.F. (60%)
ALLOWED MIN. GREEN SPACE AREA:	34,447 S.F. (40%)
ACTUAL TOTAL IMPERVIOUS SURFACE AREA:	44,200 S.F. (51%)
ACTUAL TOTAL GREEN SPACE AREA:	41,918 S.F. (49%)

OGDEN CONSTRUCTION REMODEL

11113 W. FOREST HOME AVE.
FRANKLIN, WI
SHEET TITLE:

PROPOSED SITE DEVELOPMENT PLAN & DETAILS

C-1

DATE: DEC. 1, 2014
PROJECT NUMBER: 14-005

REVISIONS:
12/1/14: PRELIM #1
12/23/14: CD'S ISSUED
1/26/15: UPDATED CD'S
2/6/15: UPDATED CD'S
3/25/15: TENANT LAYOUT
10/4/17: PARKING LOT
11/29/17: UPDATED PARKING

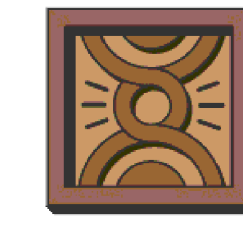

PATERA LLC
Excellence in Architecture
2601 S. Sunny Slope Rd. • New Berlin, WI 53151
Phone: 262-786-6776 Fax: 262-786-7036

COPYRIGHT: PATERA LLC...IT IS UNLAWFUL FOR ANYONE TO USE OR REPRODUCE BY ANY MEANS ALL OR ANY PORTION OF THESE CONSTRUCTION DOCUMENTS WITHOUT THE EXPRESSED WRITTEN PERMISSION OF PATERA LLC.